	Document type	Rev. number	00
	Form	Date	15-03-2018
Title	Site Specific Requirements General Part	Created by	HvB
		Checked by	
		Page	1 of 13
		Owner	WP ON EMEA PM T&C
			Restricted

Project information	
Project name:	Pottendijk
Country:	The Netherlands
Employer:	Energiepark Pottendijk
Contractor:	Siemens Gamesa Renewable Energy



Revisions				
Rev.	Date	Change	Responsible	Checked
01				
02				
03				

Printed version is uncontrolled. Controlled version only exists in the electronic document database.



	Document type <h2 style="text-align: center;">Form</h2>	Rev. number 00 Date 15-03-2018 Created by HvB Checked by Page 2 of 13 Owner WP ON EMEA PM T&C
Title <h1 style="text-align: center;">Site Specific Requirements General Part</h1>		Restricted

Table of Contents

1	GENERAL.....	3
1.1	Purpose	3
1.2	Scope of Application and Validity.....	3
1.3	Abbreviations and Definitions	3
2	RESPONSIBILITY AND AUTHORITY	6
3	INSTRUCTION AND ACTIONS.....	7
3.1	Basis of Design.....	7
3.1.1	General Design	7
3.1.2	Geotechnical Investigations for Roads and Hardstands	7
3.1.3	Design Methodology.....	7
3.1.4	Construction Supervision.....	8
3.1.5	Documentation.....	8
3.1.6	Example of site layout	10
3.1.7	Slopes and trenches.....	11
3.1.8	Drainage	11
3.1.9	Crossings.....	11
3.2	Overhead Power Lines.....	11
3.3	Completion.....	12
3.3.1	General.....	12
3.3.2	Trial Run	12
4	Abstract - Eurocode 7, EN 1997-1 : Geotechnical design, Part 1: General rules.....	13
5	Abstract – Eurocode 7, EN 1997-2: Geotechnical design, Part 2: Ground investigation and testing.....	13
6	APPENDICES.....	13

Printed version is uncontrolled. Controlled version only exists in the electronic document database.

	Document type Form	Rev. number 00 Date 15-03-2018 Created by HvB Checked by Page 3 of 13 Owner WP ON EMEA PM T&C
Title Site Specific Requirements General Part		Restricted

1 GENERAL

1.1 Purpose

This document contains the minimum requirements for the Employer provided Site Infrastructure.

The document specifies the general requirements for the Access Roads, Site Roads, Assembly Areas, Construction Areas and Installation Areas to be used for the delivery of Contractor's scope of work. Furthermore, this document defines minimum requirements to be fulfilled by the Employer with respect to Compound and Storage Areas.

The document also specifies the necessary steps the Employer shall fulfill regarding the investigation, design, construction and documentation for the required infrastructure.

Limitations:

This document does not take into account the dynamic effects, acceleration and deceleration, sloping road- and slippery road surface, weather conditions, conditions of the transport equipment and road friction coefficient.

The requirements are based on idealized situations and applied safety factors to allow real life variations based on experience and judgements.

We will work with you to adjust the requirements where possible to meet the site specific conditions

Safety shall always be the ruling factor in all situations.



1.2 Scope of Application and Validity

This instruction applies to all projects where the Contractor (or Turbine Supplier hereafter referred to as the Contractor) will perform the transportation, erection and installation work.

Non-conformances with these specifications can cause major problems, e.g. for transport, mounting and handling of the turbine components.

1.3 Abbreviations and Definitions

TSA: Turbine Supply Agreement - The Conditions of Contract

WTG: Wind Turbine Generator - As defined in the TSA

SWT: Siemens Wind Turbine

Contractor: Siemens Gamesa Renewable Energy

Employer: Energiepark Pottendijk

Printed version is uncontrolled. Controlled version only exists in the electronic document database.

	Document type	Rev. number	00
	Form	Date	15-03-2018
Site Specific Requirements General Part	Created by	HvB	
	Checked by		
	Page	4 of 13	
	Owner	WP ON EMEA PM T&C	
		Restricted	

Figure 1 below shows the placements and boundaries of the terms used in this document.

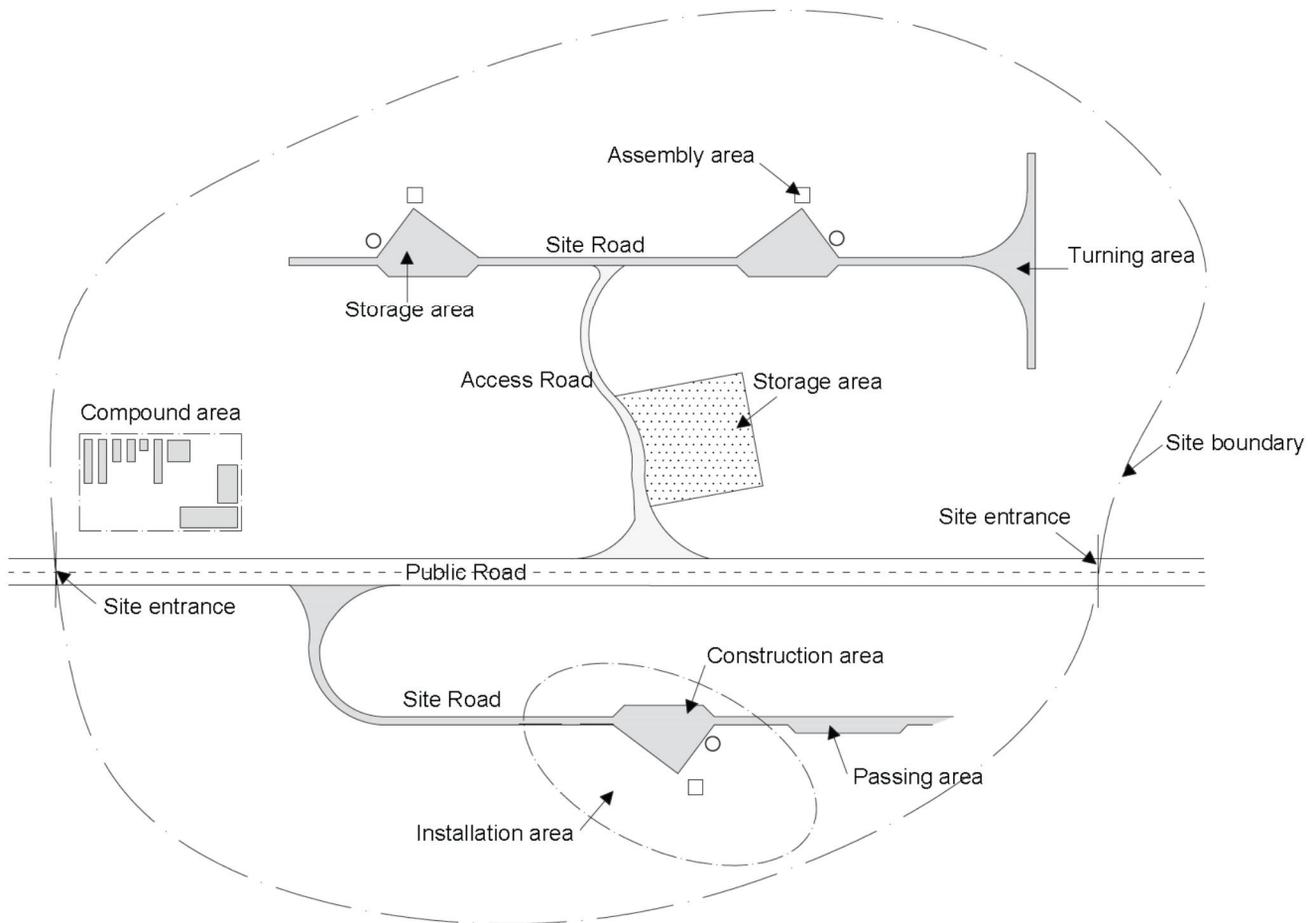



Figure 1: An Example of a Site.

Definitions:

- Access Road** Road connecting Public Road to the Site. This road can be Public Road or part of the Site Infrastructure.
- Area(s)** Means the Assembly Area, the Compound Areas, the Construction Area, the Installation Area and the Storage Area, or one of them, as the context requires.
- Assembly Area** Area on Site where the hub can be stored and where the rotor is assembled prior to the installation of the complete rotor. The area is only relevant for the Rotor Assembly Installation Method and Single Blade with Ematec.
- Assist Crane** A crane helping to rig/de-rig the Main Crane and supporting the Main Crane in the WTG erection.
- Construction Area** The part of the Installation Area located at each WTG foundation position which is required for assembling and operating the cranes, containers for lifting equipment, generator unit, working area with tools and containers etc.

Printed version is uncontrolled. Controlled version only exists in the electronic document database.

	Document type Form	Rev. number 00 Date 15-03-2018 Created by HvB Checked by Page 5 of 13 Owner WP ON EMEA PM T&C
Title Site Specific Requirements General Part		Restricted

Hardstand An improved / stabilized area with a prepared surface where cranes can operate, vehicles can be parked and material / components can be stored. Hardstand is also a general expression used for Construction Area. The bearing capacity of the hardstand is stated in Appendix 1.

Installation Area The entire working area needed when erecting a WTG. The area consists of several areas, each with different requirements. The Installation Area consists of an Assembly Area, Construction Areas for the cranes and Trestle Areas.

Main Crane A crane capable of lifting the WTG components into the final position.

Passing Area Area where Transport Vehicles safely can pass each other.

PU Power Unit.

Public Road Road that is open for public use and is maintained by a public authority.

Pre-Assembly Assembly of certain WTG components that do not require the Main Crane for installation.

Rotor Assembly Installation Method Method where the hub and the blades are assembled on ground prior to lifting of the entire rotor.

Service Period Requirements Requirements given in this document for the Site Roads and Areas that the Employer must achieve in order for the Contractor to operate and maintain the WTGs in the agreed service and defects notification period.

Single Blade Installation Method Method where the hub and the blades are installed individually.

Site The place where the installation works are to be executed and to which all materials are to be delivered as defined in the Contract.

Site Boundary The area where requirements given in this document must be achieved by the Employer in order for the Contractor and his sub-contractors to operate safely and efficiently during the construction phase and the service and defects notification period. The delimited area is shown in **Figure 1**.

Site Entrance The Site Entrance is the official entrance to the Site.

Site Infrastructure General expression in this document for the Site Roads, Areas and Hardstands within the Site Boundary.

Site Facilities Compound Area The base area for the Contractor's site management and technicians. The area consists of restroom facilities, parking and site offices. In some cases, the Site Facilities Compound Area may be combined with the Stores Compound Area.

Site Roads Roads within the Site Boundary.

Storage Area The lay down area for WTG components and tools. Depending on the Site Infrastructure, the Storage Area can be placed in connection with the Construction Area where it can be used as a Passing Area as well.

Stores Compound Area The base area for the Contractor's technical equipment including, but not limited to, plant, skips, waste disposal, tool containers, spares and fuel. In some cases, the Stores Compound Area may be combined with the Site Facilities Compound Area.

SU Switch gear unit.

Printed version is uncontrolled. Controlled version only exists in the electronic document database.

	Document type <h2 style="text-align: center;">Form</h2>	Rev. number 00 Date 15-03-2018 Created by HvB Checked by Page 6 of 13 Owner WP ON EMEA PM T&C
Title <h1 style="text-align: center;">Site Specific Requirements General Part</h1>		Restricted

Transport Vehicle General expression in this document for WTG and crane component transportation vehicles as well as cranes.

Trestle Area Area where the blades are stored on the Installation Area.

TU Transformer Unit.

Turning Area Area where the Transport Vehicles can turn around to prevent long reverse driving.

2 RESPONSIBILITY AND AUTHORITY

The Employer shall design, construct and maintain the Site Infrastructure described within this schedule or exhibit in accordance with the Contract.

Site Infrastructure shall be functional at all times for heavy cranes, oversize trucks and the Contractor's personnel vehicles involved in the project execution, warranty period as well as the service and maintenance period. All Site and Access Roads shall be in good condition, maintained and repaired at all times (and under all weather conditions) by the Employer, including for example the clearance of water, snow, ice, hail, mud, debris, filling of pot holes etc. as required. The Employer shall also ensure that safe access is provided to the access point of the turbine at all times.

The detailed location of the roads and Areas are defined in Schedule / Exhibit J1.

The Employer and the Contractor shall each be responsible for their own traffic management and other traffic safety related activities within the Site Boundary. However, the Employer has the overall responsibility for the traffic management and other traffic safety related activities within the Site Boundary.

If the Employer becomes aware of road access restrictions, the Employer shall inform the Contractor of such restrictions as soon as reasonably possible thereafter.

The Employer remains at all times solely responsible for conducting investigations and designs according to this document. The Contractor's comments to the performed investigations and designs shall under no circumstances relieve the Employer of his responsibility, and the Contractor shall not be liable for any such comments.

Printed version is uncontrolled. Controlled version only exists in the electronic document database.

	Document type Form	Rev. number 00 Date 15-03-2018 Created by HvB Checked by Page 7 of 13 Owner WP ON EMEA PM T&C
Title Site Specific Requirements General Part		Restricted

3 INSTRUCTION AND ACTIONS

3.1 Basis of Design

3.1.1 General Design

Design of the Site Infrastructure including all Areas and Hardstands must be performed by the Employer in accordance with the laws and legislation applicable in the country where the wind farm is being developed, and with a consistent set of design codes, to yield a sufficient level of safety and suitability.

The present document generally refers to the Eurocode system with relevant National Annexes. Where appropriate, similar national standards yielding a level of safety comparable with the Eurocode system, may be used.

The Employer must pay due attention to the concentrated nature of loads. In particular, caution shall be applied with regards to assumed pressure distribution through the unbound base layers.

The design shall be performed taking into account the quality of the building materials that can be obtained for the works. The National Annexes of the Eurocodes and Gravel Roads Maintenance and Design Manual (by Ken Skorseth and Ali A. Selim, 2000) give guidelines for suitable material for the construction of the Site Infrastructure.

The design shall be performed based on the geometric requirements and applying loads as specified in Appendix 1 of this document.

3.1.2 Geotechnical Investigations for Roads and Hardstands

Eurocode 7, EN 1997-2, Ground investigation and testing, is the ruling code to be applied by the Employer in collecting geotechnical data. The Employer shall plan geotechnical investigations in such a way as to ensure that relevant geotechnical information is adequate to manage identified and anticipated project risks. EN 1997-2, annex B, gives informative guidelines for the level and planning of geotechnical investigations.

3.1.3 Design Methodology

The Employer shall perform road design by using an empirical analytical method where actual stresses and strains in the pavement structure is calculated and compared with allowable stresses and strains. This method may be based on the simplified loads given in Appendix 1 (single wheel load, contact pressure and numbers of passes) and measured sub grade moduli.

The above described method will allow for variable thickness between the most frequently used parts of the site road network and the part of the road network that will have the lowest frequency of traffic.

The design has to be based on the local material properties (E-moduli/CBR) and the appropriate local criteria for these.

Alternatively, the road design can be based on national standard methods applying the detailed loads listed in Appendix 1.

The Employer's design of Hardstands shall be based on an analytical determination of the geotechnical bearing capacity for the Hardstands applying loads as listed in Appendix 1 from the time of the plate bearing tests onwards.

Printed version is uncontrolled. Controlled version only exists in the electronic document database.

	Document type <h2 style="text-align: center;">Form</h2>	Rev. number 00 Date 15-03-2018 Created by HvB Checked by Page 8 of 13 Owner WP ON EMEA PM T&C
Title <h1 style="text-align: center;">Site Specific Requirements General Part</h1>		Restricted

3.1.4 Construction Supervision

To ensure that design conditions are fulfilled, construction supervision is crucial. The Employer shall ensure that construction supervision is carried out in accordance with EN 1997-1 using skilled personnel regarding:

- Ground conditions;
- Compaction control;
- Ground-water flow;
- Movements, yielding, stability of excavation walls and base;
- Safety of workmen with due consideration of geotechnical limit states.

3.1.5 Documentation

To facilitate a proactive dialogue about the layout and design of roads, Areas and Hardstands, the Employer shall submit the following documentation to the Contractor or their sub-contractors for review and possible commenting. Please note that the Contractor's possible comments to the design are in no way to relieve the Employer of its responsibilities under the Contract.

The Employer shall submit the following documentation to the Contractor for review:

- Prior to the construction of the infrastructure within the Site Boundary such as roads and Hardstands, the Employer shall present designs and documentation to the Contractor for review.
- No later than 4 months prior to commencing delivery of any WTG components, the Employer shall provide a detailed layout of the project site identifying the construction status of the roads and Hardstands.
- As built drawings of Hardstands shall be provided as specified in Schedule C [Contract Programme].
- Results of each hardstand plate bearing tests shall be available upon request at least one month before in Schedule C [Contract Programme]. The Contractor shall be permitted to specify the locations of minimum four plate bearing tests at each hardstand.
- Any additional results of geotechnical investigations
- Designs of the site layout including cross sections and material specifications
- Construction supervision reports
- Quality control documentation and test results
- Verification of load bearing capacity and estimation of settlements for the Main Crane area
- Verification of load bearing capacity for remaining hardstands (auxiliary crane, assembly and storage areas) and roads
- Verification of site-specific / special geotechnical matters (e.g. slope stability, soil improvement)
- Verification tests of compaction of the subgrade and of each fill layer
- Type and quantity of suitability testing (e.g. particle size distribution, proctor test) of the construction materials
- Type and quantity of verification testing (e.g. static plate load test)
- Acceptance criteria for testing (e.g. Ev1 and Ev2 for static plate load tests)
- Maximum allowable total settlement shall not exceed 2cm for the specified maximum loads applied for the period of two weeks on crane hardstands

Printed version is uncontrolled. Controlled version only exists in the electronic document database.

	Document type <h2 style="text-align: center;">Form</h2>	Rev. number 00 Date 15-03-2018 Created by HvB Checked by Page 9 of 13 Owner WP ON EMEA PM T&C
Title <h2 style="text-align: center;">Site Specific Requirements General Part</h2>		Restricted

- Minimum four tests per Hardstand with at least two tests in the area of the Main Crane area
- Minimum one test for every 500m of road

The test locations shall be selected considering the loading areas and in consultation with the geotechnical expert in order to ensure that the results reflect the representative subsoil conditions.

If the subsoil conditions are heterogeneous the testing schedule needs to be adjusted by a geotechnical expert.

If the subsoil conditions differ substantially from the geotechnical investigation, additional geotechnical investigations shall be performed and the design shall be reviewed / adjusted.

A common in-situ test is the static plate load test as per DIN 18134 (or equivalent international standard). The testing shall be carried out with a suitable sized plate preferably at least 60cm. Dynamic load test can be considered if prior calibration has been made with static plate load test.

In general plate load tests are only suitable for testing the compaction grade of superficial soil layers to a very limited depth. Since deeper soil layers may significantly influence the bearing capacity and settlement behaviour of the soil structure under the applicable construction loading it may be prudent to apply also suitable penetrative soil exploration methods.

The Employer shall provide in dwg. (cad) or similar format drawings of the Site Infrastructure:

- as-planned drawings: 20 weeks before contractual start of installation
- as-built drawings 5 weeks before contractual start of installation

3 weeks prior to start of turbine delivery the Employer shall provide a Certificate that confirms the roads and the Hardstands are suitable for the purpose and comply with the requirements in this document.

The Statement or Certificate shall be supplemented by the results of the performed verification tests (plate load tests).

The Hardstands and roads shall be subject to regular inspections, which shall be documented in field inspection logs, by a competent individual appointed by the Customer. Any inadequate areas identified must be reinstated to the designed standard.

Prior to the handover of Compound, Storage & Facilities and each WTG Hardstand, the Contractor and Employer shall complete the checklist (provided in Appendix 2).

Printed version is uncontrolled. Controlled version only exists in the electronic document database.

	Document type	Rev. number	00
	Form	Date	15-03-2018
Title Site Specific Requirements General Part	Created by	HvB	Checked by
	Page	10 of 13	Owner
	Owner	WP ON EMEA PM T&C	Restricted

3.1.6 Example of site layout

The figures below show examples of road infrastructure for safe delivery of WTGs. Detailed discussions can be held between the Contractor and Employer to find the best and cost effective solution.

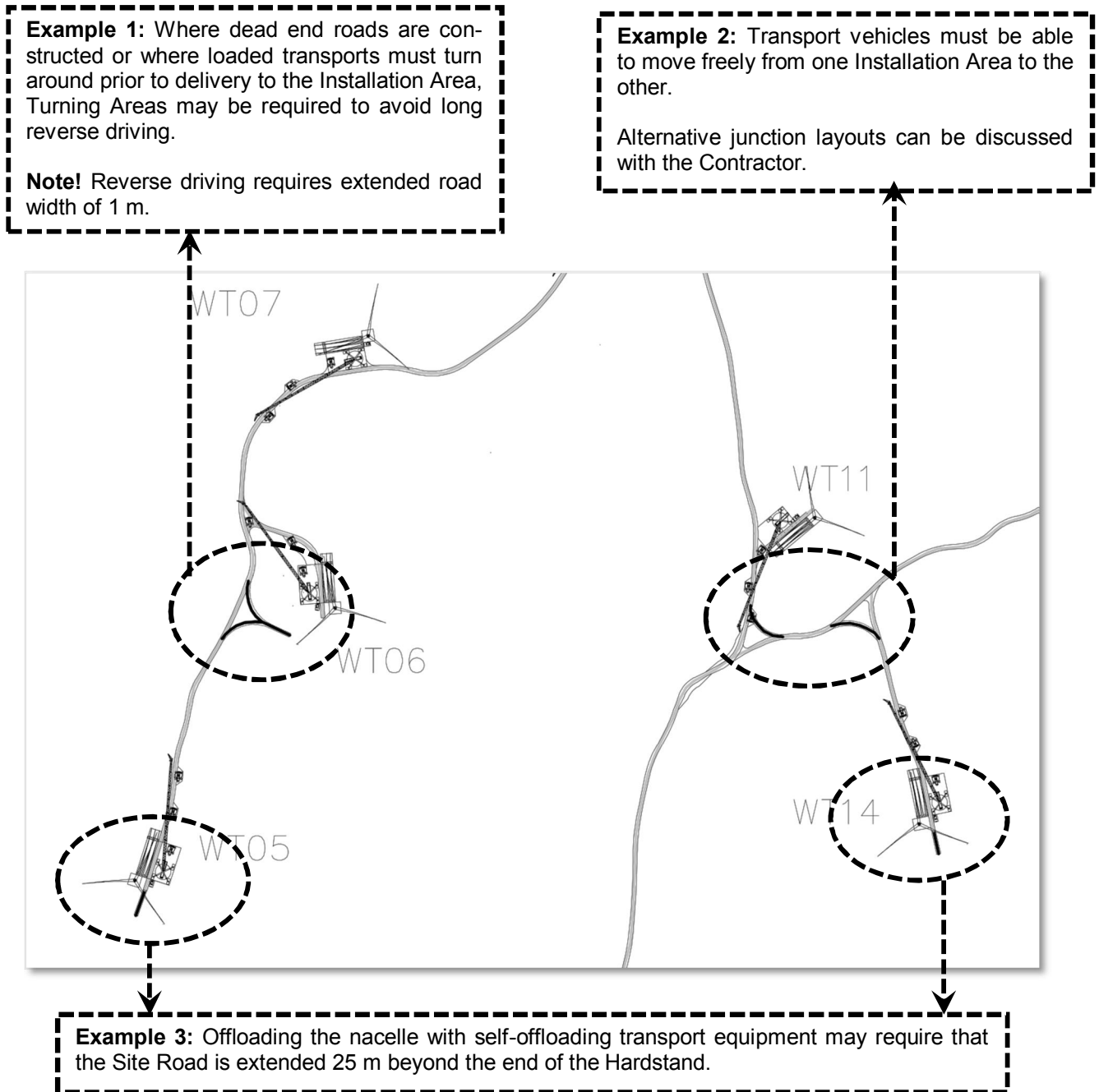

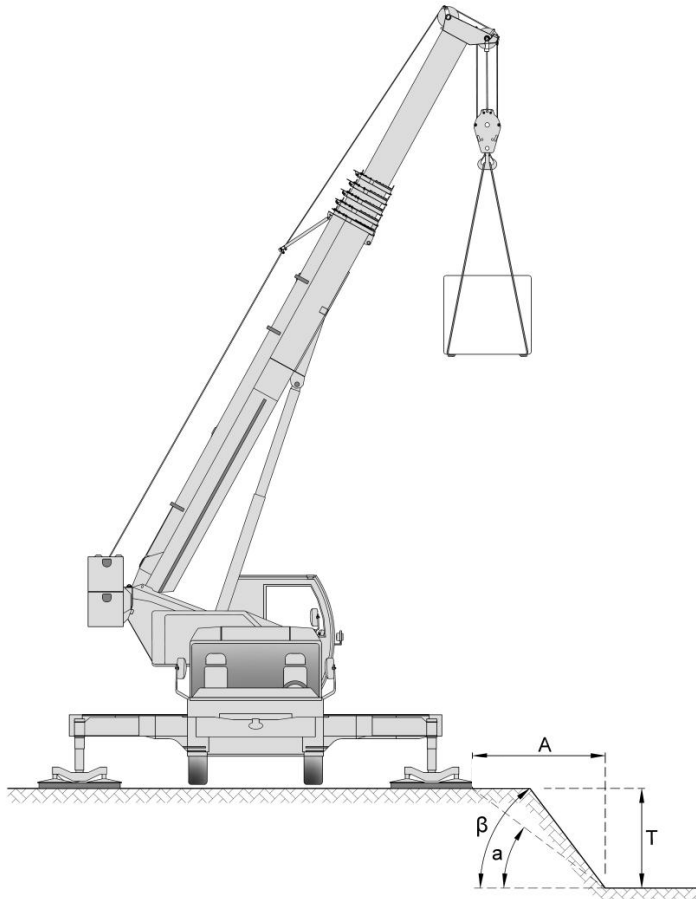

Figure 2: Example of site layout. The detailed project site infrastructure is provided in Schedule J1.

Printed version is uncontrolled. Controlled version only exists in the electronic document database.

	Document type <h2 style="text-align: center;">Form</h2>	Rev. number 00 Date 15-03-2018 Created by HvB Checked by Page 11 of 13 Owner WP ON EMEA PM T&C
Title <h1 style="text-align: center;">Site Specific Requirements General Part</h1>		Restricted

3.1.7 Slopes and trenches



Heavy loads must not be set up too close to slopes or trenches. Depending on the soil type, a safe distance must always be kept from the edges.

It is the Employer's responsibility to ensure that there is sufficient load bearing capacity within the Areas required in this document.

As ground conditions and building material can vary from place to place, safety margins are not included in this document.

Please refer to Appendix 1 for requirements regarding Hardstand geometry and level differences.

Figure 3: Requirements for setting up the crane near slope or trench.

3.1.8 Drainage

Along the Site Roads and Hardstands, sufficient drainage shall be included by the Employer to ensure that Site Roads and Hardstands are functional in all weather conditions, ref. section 2.

3.1.9 Crossings

The Employer shall arrange for the fortification of earthworks and bridges on Site at points of crossing along pipelines and other underground services. Design of the necessary fortification shall be based on loads specified in **Appendix/Appendices**.

3.2 Overhead Power Lines

Any LV/HV power or communication lines crossing Site Roads shall be clearly marked by the Employer and raised where required to provide the height clearance as per Appendix 1, Table 1.

Printed version is uncontrolled. Controlled version only exists in the electronic document database.

	Document type <p style="text-align: center;">Form</p>	Rev. number 00 Date 15-03-2018 Created by HvB Checked by Page 12 of 13 Owner WP ON EMEA PM T&C
Title <p style="text-align: center;">Site Specific Requirements General Part</p>		Restricted

3.3 Completion

3.3.1 General

The Employer shall make an inspection after completion of Site Infrastructure in order to ensure that all requirements have been implemented correctly. Upon completion of this, the Employer shall contact the Contractor, who may perform his independent inspection. This shall however not relieve the Employer from his obligations as set out in this document.

The Hardstand/Foundation handover checklist at Appendix 2 shall be used by the Contractor and Employer to document all areas not meeting the requirements specified herein. The Employer shall ensure all such comments are rectified prior to the date specified in Schedule C [Programme]. The Contractor and Employer shall review this checklist on a regular basis thereafter (as mutually agreed but no less than every 2 weeks) to ensure all areas are appropriately maintained.

3.3.2 Trial Run

A trial run shall be carried out as soon as possible after the completion of the Site Infrastructure. The trial run shall be completed at the latest 4 weeks prior to the WTG delivery commencement date as specified by the Contractor (excluding scheduled delivery of foundation parts).

Type and configuration of the vehicle used for the trial run shall be decided by the Contractor.

Site Infrastructure which does not comply with the requirements as set out in this document, shall be upgraded by and at the expense of the Employer, prior to the WTG delivery commencement date as specified by Contractor. Failure to accomplish such upgrades prior to the turbine delivery commencement date as specified in Schedule C will result in an extension of time for completion and compensation of additional cost to the Contractor in accordance with the TSA.

Printed version is uncontrolled. Controlled version only exists in the electronic document database.

	Document type	Rev. number 00
	Form	Date 15-03-2018
Title Site Specific Requirements General Part		Created by HvB
		Checked by
		Page 13 of 13
		Owner WP ON EMEA PM T&C
		Restricted

4 **Abstract - Eurocode 7, EN 1997-1 : Geotechnical design, Part 1: General rules**

EN 1997-1 is intended to be used as a general basis for the geotechnical aspects of the design of buildings and civil engineering works. The following subjects are dealt with in EN 1997-1:

- Section 1: General
- Section 2: Basis of geotechnical design
- Section 3: Geotechnical data
- Section 4: Supervision of construction, monitoring and maintenance
- Section 5: Fill, dewatering, ground improvement and reinforcement
- Section 6: Spread foundations
- Section 7: Pile foundations
- Section 8: Anchorages
- Section 9: Retaining structures
- Section 10: Hydraulic failure
- Section 11: Overall stability
- Section 12: Embankments

EN 1997-1 is accompanied by Annexes A to J, which includes:

Annex A: recommended partial safety factor values; different values of the partial factors may be set by the National annex.

Annexes B to J: supplementary information.

5 **Abstract – Eurocode 7, EN 1997-2: Geotechnical design, Part 2: Ground investigation and testing**

EN 1997-2 is intended to be used in conjunction with EN 1997-1 and provides rules supplementary to EN 1997-1 related to:

- Planning and reporting of ground investigations
- General requirements for a number of commonly used laboratory and field tests
- Interpretation and evaluation of test results
- Derivation of values of geotechnical parameters and coefficients

6 **APPENDICES**

Appendix No.	Title	Number of pages
1	Site Specific Requirements – SWT DD-130-85mHH	28
2	Site Specific Requirements Handover Checklist	2
3	SSR Handover Certificate	1

Printed version is uncontrolled. Controlled version only exists in the electronic document database.

	Document type	Rev. number	00
	Appendix	Date	15-03-2018
Title	Appendix 1: Site Specific Requirements SWT 3,6MW-130-85,0HH	Created by	HvB
		Checked by	MB
		Page	1 of 28
		Owner	WP ON EMEA PM T&C
			Restricted

WTG information

Turbine type:	SWT3,6MW-130	
Hub Height:	85,0	
Amount of tower sections:	3	
Amount of WTGs:	12	
Installation method:	Rotor assembly	
Main crane:	LG1750 or similar	
Pre-assembly set-up:	Yes, with 500t crane (84m)	
Assist crane:	100t / 200t	

Component Specifications		<i>NOTE: Dimensions and weights are only indicative!</i>			
Component	Length [m]	Width or diameter (large diameter) [m]	Height or diameter (small diameter) [m]	Weight [t]	
B63 blades (per blade)	63.45	4.10	2.63	17.200*	
Hub	5.25	4.81	4.20	45.914	
Nacelle	6.08	4.14	4.18	33.000	
Generator	2.60	4.18	4.18	70.300	
D3-T85.0-473	Tower Top Section	36.00	4.22	2.96	76.879
	Tower Mid-Section 1	31.64	4.30	4.22	69.022
	Tower Base Section	14.98	4.50	4.30	63.715

**weights with bolts*

Revisions				
Rev.	Date	Change	Responsible	Checked
01				
02				
03				
04				

Printed version is uncontrolled. Controlled version only exists in the electronic document database.



	Document type <h2 style="text-align: center;">Appendix</h2>	Rev. number 00 Date 15-03-2018 Created by HvB Checked by MB Page 2 of 28 Owner WP ON EMEA PM T&C
Title <h3 style="text-align: center;">Appendix 1: Site Specific Requirements SWT 3,6MW-130-85,0HH</h3>		<div style="text-align: center;">Restricted</div>

Table of Contents

1	ROAD GEOMETRY	3
1.1	Road Marking.....	3
1.2	Road Surface.....	3
1.3	Road Width and Cross Fall.....	4
1.4	Gradient and Longitudinal Radius.....	5
1.5	Road Bends and Junctions.....	6
1.6	Passing and Turning Areas	7
2	INSTALLATION AREA.....	9
2.1	General Information for SWT Installation Area.....	9
2.2	Construction Area	9
2.2.1	Option 1 Modified Rectangular Hardstand	10
2.2.2	Transformers.....	13
2.2.3	WTG Door Location.....	13
2.2.4	Safe Working Access	13
2.2.5	Hardstand for Main Crane q1.....	14
2.2.6	Hardstand for Assist Crane q2.....	14
2.2.7	Hardstand for Assist Crane q2 (on slopes).....	15
2.2.8	Rotor Assembly Installation Method.....	16
2.2.9	Trestle area for blades q4.....	17
2.2.10	Hardstand for boom assembly q6	18
2.3	Level differences and access to WTG.....	19
2.4	Area for Tag Lines.....	20
2.5	Proposed Delivery Methodology	22
3	Facilities Compound & Storage Area Requirements	23
3.1	Site Facilities Compound Area.....	23
3.2	Stores Compound Area.....	23
3.3	Storage Area for WTG Components	23
4	LOADS	24
4.1	General.....	24
4.2	Crane Load	24
4.3	Other Loads	25
5	TRANSPORT.....	26
5.1	Method 1: The empirical analytical method.....	26
5.2	Method 2: Maximum characteristic loads of transport vehicles.	26
5.3	Transport drawings	27

Printed version is uncontrolled. Controlled version only exists in the electronic document database.

	Document type <h2 style="text-align: center;">Appendix</h2>	Rev. number 00 Date 15-03-2018 Created by HvB Checked by MB Page 3 of 28 Owner WP ON EMEA PM T&C
Title <h3 style="text-align: center;">Appendix 1: Site Specific Requirements SWT 3,6MW-130-85,0HH</h3>		Restricted

1 ROAD GEOMETRY

1.1 Road Marking

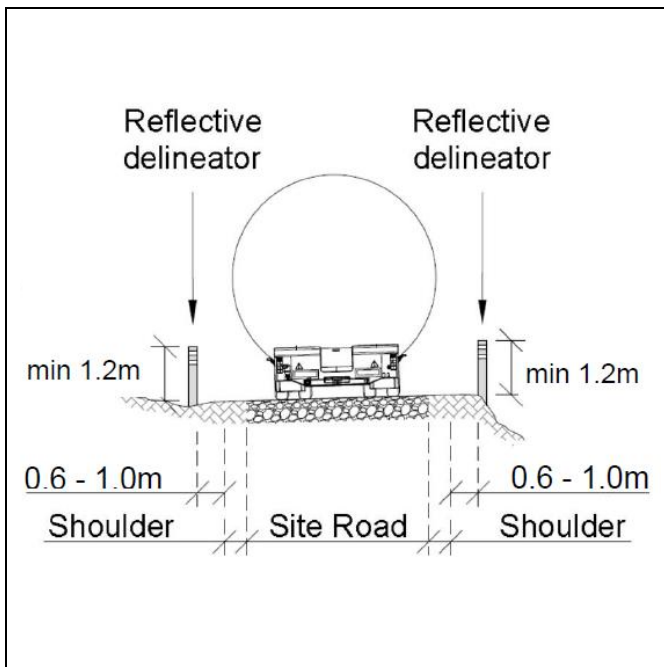

Figure 1: Placing of delineators by the road.

The Employer shall clearly mark the Site Roads with full bearing capacity (marked as **B** in **Table 1** and **Figure 4**).

Reflective delineators or similar device shall be mounted along dangerous and complicated road stretches.

Top of the reflector shall be min. 1.2m above the road surface. They shall be placed 0.6m to 1.0m outside the edge of the shoulder at a constant distance from the edge of the Site Road.

They shall be spaced a maximum of 60m apart on mainline sections and shall be spaced a maximum of 30m apart on ramp and curved sections. For curved sections, a pair of markers will be used to mark the start and finish of the curved section, as well as the apex of the bend.

Delineators may need to be removed for certain component deliveries (e.g. to allow for blade oversail) and in such cases, the Employer shall arrange for their removal and reinstatement.

1.2 Road Surface

Roads and hardstands shall be constructed as per **Figure 4** & **Figure 11**, surfaced using Type 2 material in accordance with the Specification for Highway Works, Clause 804 (i.e. from 63mm down and well graded), to ensure suitable surface for operations throughout performance of the works. For example:

- Site and Access Roads shall be regularly rolled to prevent large stones causing damage to cranes and other vehicles.
- Large pot holes can cause damage to cranes and other vehicles and in extreme cases also present a hazard for vehicle operatives. Therefore, the road shall be maintained as per the original design at all times to ensure there are no pot holes larger than that shown in **Figure 2**.
- The Employer shall be responsible for ensuring systems are in place to avoid excessive dirt / debris being deposited onto the public roads e.g. road sweeping or provision of wheel wash facilities as required. The Contractor shall cooperate with the Employer and other sub-contractors in relation to such systems of work.
- The road surface should provide suitable traction to allow a single tractor unit on the component trailer to transport all components up to a gradient of 11% (or 18% with the addition of an 8x4 pulling unit, if included in our proposal). If suitable traction cannot be achieved due to surface quality or weather conditions prevalent at the time of transportation, then the time/cost of additional units will be at the expense of the Employer.

Printed version is uncontrolled. Controlled version only exists in the electronic document database.

	Document type	Rev. number	00
	Appendix	Date	15-03-2018
Title	Appendix 1: Site Specific Requirements SWT 3,6MW-130-85,0HH	Created by	HvB
		Checked by	MB
		Page	4 of 28
		Owner	WP ON EMEA PM T&C
			Restricted



Figure 2: A well maintained Site Road shall not have potholes deeper than 30mm and/or a distribution/collection of potholes that at the reasonable discretion of the Contractor cause unsuitable or unsafe driving conditions.



Figure 3: Example of a well groomed gravel road with a slope for proper drainage.

1.3 Road Width and Cross Fall

Due to the loads from transport vehicles, the Employer shall ensure a sufficient width of the road shoulders in order to obtain full bearing capacity for the road with the width **B**.

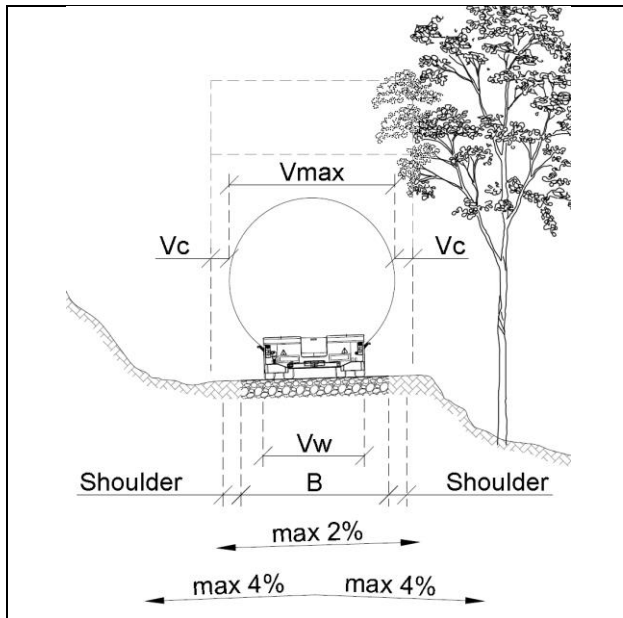

Figure 4: Road width and cross fall.

Min. width with full bearing capacity = B	4 m
Width of shoulders	X m*
Width of truck = Vw	3 m
Min. clearance on both sides = Vc	0.5 m
Width of component = Vmax	4.8 m
Max. lateral slope – Ordinary road profile	2 %
Max. lateral slope – Road roof profile (both sides)	4 %
Min. height clearance (Access/Site Road to first WTG)	6 m
Min. height clearance (Site Roads between WTGs)	8 m

Table 1: Requirements for Site Roads.

**It is the Employer's responsibility to design the shoulders so that they provide adequate support for the 4m of driving surface.*

NOTE: Reverse driving and any areas requiring pulling units as detailed (in **Table 2**) shall require the road width to be extended by a minimum of 1m. Reverse driving and push pull unit usage is possible on straight roads up to a maximum of approximately 500m. *Locations requiring reverse driving and push pull units shall be pre-determined as part of the Site setup discussions.*

Printed version is uncontrolled. Controlled version only exists in the electronic document database.

	Document type	Rev. number	00
	Appendix	Date	15-03-2018
Title	Appendix 1: Site Specific Requirements SWT 3,6MW-130-85,0HH	Created by	HvB
		Checked by	MB
		Page	5 of 28
		Owner	WP ON EMEA PM T&C
			Restricted

1.4 Gradient and Longitudinal Radius

Assuming a reasonably straight road without narrow curves, the maximum allowable gradient and longitudinal radius on roads is stated in **Table 2**. The gradients shall be gradual and measured over an approximate distance of 12 metres.

Road	Longitudinal Radius (R_{min})	Gradient*	With Pulling Unit*
For WTG component transports	500 m	11%	18%
For reverse driving (positive & negative gradients)	500 m	4%** ,***	4 to 8%** ,***
Crane Partially De-rigged	-	13%	-
Crane Fully De-rigged	-	18%	-

Table 2: Gradient and longitudinal radius. The requirements above are based on a lattice boom crane as it is the assumed crane type to be utilised for this project. Should a different crane type be required or proposed, the Contractor shall discuss and agree the requirements with the Employer prior to Contract Effective date.

*For gradients bigger than 11% and up to a maximum of 18%, a pulling unit (as shown in **Figure 6**) is required. The use of pulling units is highly dependent on conditions such as length of gradient, straight/curved roads, quality of road surface, weather conditions etc. As such, unless explicitly stated, our proposal assumes movement of the crane in a partially de-rigged configuration for all WTG locations and that no pulling units are required for the project. Siemens are happy to work with the Employer to define those areas on Site which may require either a pulling unit or full crane de-rigging. Gradients above 18%, up to a maximum of 20% are possible, but these require special pulling units and tarmac road, for the full duration of the gradient and length of the vehicle, at the top and bottom of the gradient to ensure sufficient traction throughout. Should gradients above 18% be required, we would wish to discuss this with you on a case by case basis.

**Actual achievable gradients depend on the quality of the road conditions and maintenance, and are therefore subject to Site conditions at the time of transportation. The Contractor shall identify any concerns to the Employer at the Trial Run for resolution by the Employer. Both parties shall then review the road condition on a regular basis during the transportation and installation phase to ensure the roads are maintained by the Employer in the condition agreed at the time of the Trial Run.

***Permissible gradients for reverse driving are dependent on the type of vehicle, road width and whether the gradient is uphill or downhill. When reversing uphill with a clamp truck, a gradient of 8% is only achievable on short straight sections with a 6m wide road. When reversing downhill, gradients of 8%-11% are achievable on short straight sections with a 6m road.

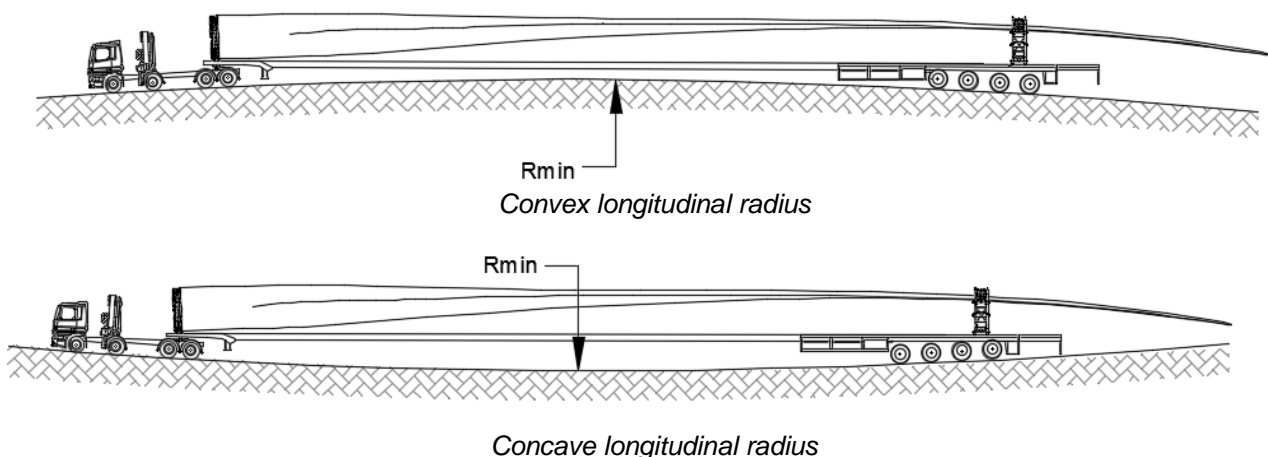



Figure 5: Longitudinal radius.

Printed version is uncontrolled. Controlled version only exists in the electronic document database.

	Document type	Rev. number	00
	Appendix	Date	15-03-2018
Title	Appendix 1: Site Specific Requirements SWT 3,6MW-130-85,0HH	Created by	HvB
		Checked by	MB
		Page	6 of 28
		Owner	WP ON EMEA PM T&C
			Restricted

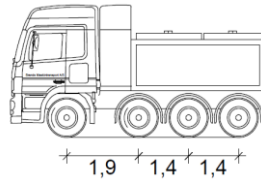

Figure 6: Example of a standard 8x4 pulling unit (4 of the 8 wheels are driven by the engine).

1.5 Road Bends and Junctions

In order to ensure safe operation for the vehicles used during construction/installation, road bends and junctions shall be constructed by the Employer according to the requirements set out in **Figure 7**. In addition:

- Road bends sharper than **90 degrees** must be custom built and discussed in detail with reference to the actual transport equipment.
- Road bends with a vertical gradient bigger than 3% over the course of the bend need to be analysed for each individual situation.

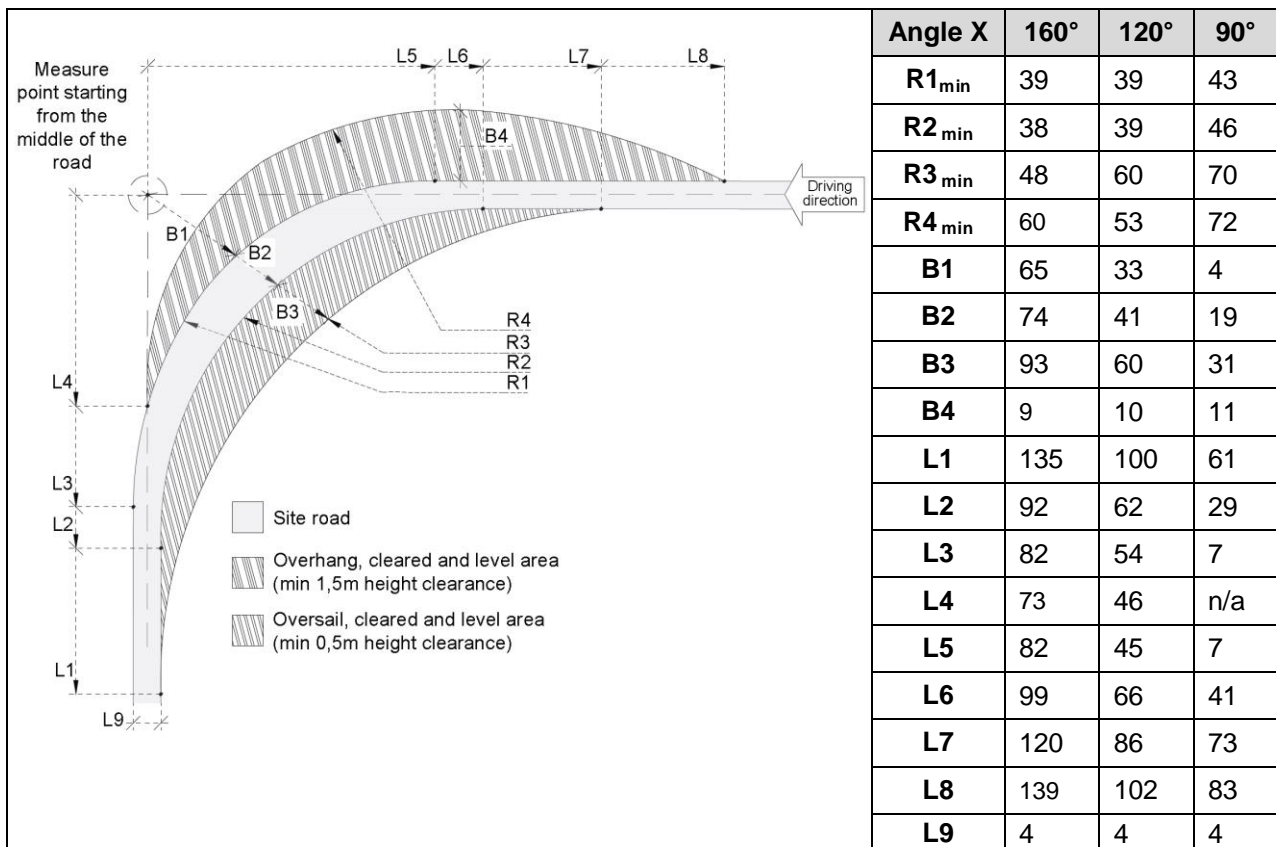



Figure 7: Example of 90° road bend.

Table 3: Requirements for road bends and junctions (in meters).

Printed version is uncontrolled. Controlled version only exists in the electronic document database.

	Document type	Rev. number	00
	Appendix		Date
Title	Appendix 1: Site Specific Requirements SWT 3,6MW-130-85,0HH	Created by	HvB
		Checked by	MB
		Page	7 of 28
		Owner	WP ON EMEA PM T&C
			Restricted

1.6 Passing and Turning Areas

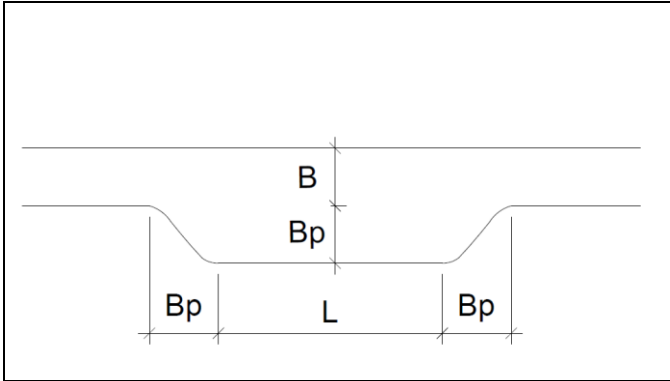

Figure 8: Example of passing area for trucks.

Depending on the road layout, logistics and choice of Hardstand arrangement, passing and/or turning areas shall be incorporated into the Site Infrastructure design. Passing places shall be provided every 500m along the Site access track and on Site as required, depending on the final Site layout. Should this cause difficulties in the design, the Contractor will assist the Employer to identify other options to ensure a smooth traffic flow e.g. one-way systems.

Requirement	Value
Length of passing (L)	25 m
Width of passing (Bp)	6 m

Table 4: Requirements for dimensioning Passing Areas.

Where dead end roads are constructed or where loaded transports must turn around prior to delivery to the Installation Area, Turning Areas are required to avoid long reverse driving. Please refer to **Figure 9 & Figure 10** for requirements relating to Turning Areas. Discussion is required between the Employer and Contractor in order to identify which Turning Areas should be constructed for loaded / unloaded trucks.

Printed version is uncontrolled. Controlled version only exists in the electronic document database.

	Document type	Rev. number	00
	Appendix	Date	15-03-2018
Title	Appendix 1: Site Specific Requirements SWT 3,6MW-130-85,0HH	Created by	HvB
		Checked by	MB
		Page	8 of 28
		Owner	WP ON EMEA PM T&C
			Restricted

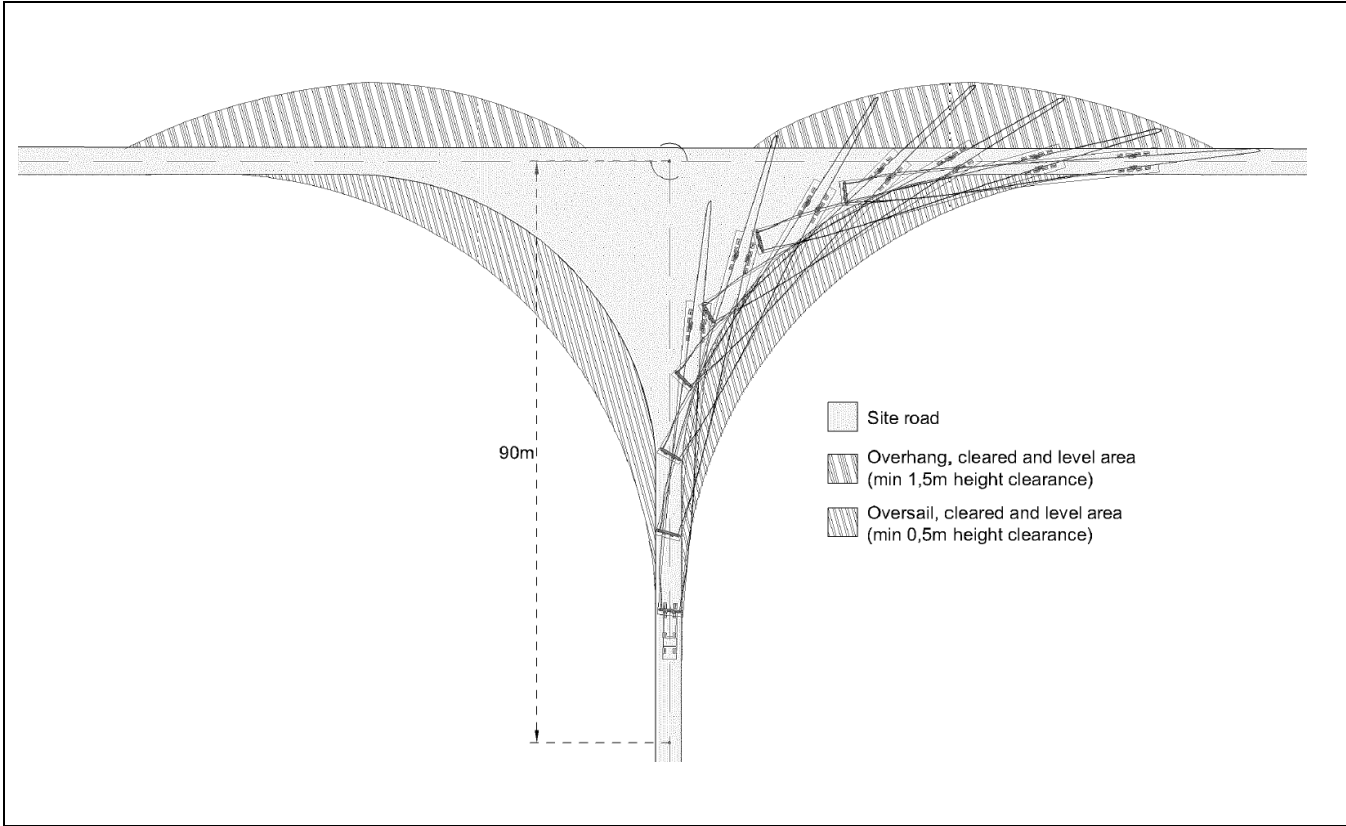
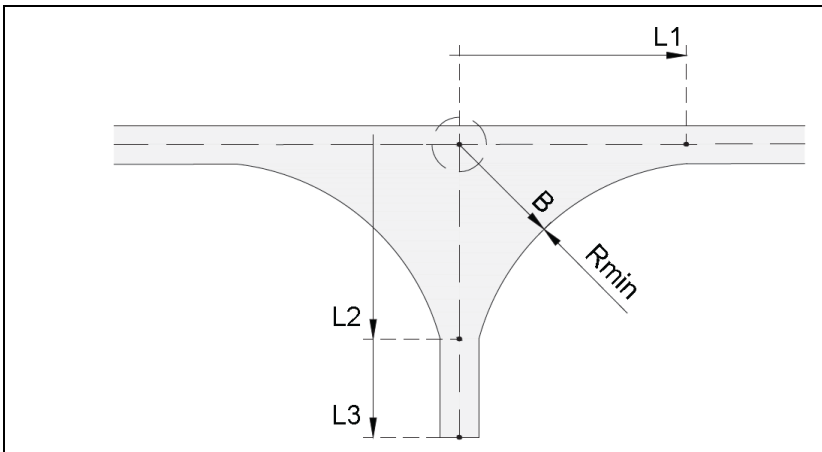

Figure 9: Turning area for **loaded truck**. Hatched areas must be cleared of obstacles and levelled to allow oversail/ overhang during transportation. See requirements for road bends and junctions to dimension the turning areas.



Angle X	90 °
R min	25 m
B	12 m
L1	22 m
L2	20 m
L3	30 m

Figure 10: Turning area for **empty truck**. Hatched areas must be with full bearing capacity and cleared of obstacles and levelled to allow oversail/overhang.

Table 5: Requirements for turning area for **empty truck**.

Printed version is uncontrolled. Controlled version only exists in the electronic document database.

	Document type <h2 style="text-align: center;">Appendix</h2>	Rev. number 00 Date 15-03-2018 Created by HvB Checked by MB Page 9 of 28 Owner WP ON EMEA PM T&C
Title <h3 style="text-align: center;">Appendix 1: Site Specific Requirements SWT 3,6MW-130-85,0HH</h3>		Restricted

2 INSTALLATION AREA

2.1 General Information for SWT Installation Area

Installation Area includes the entire working area needed when erecting a WTG. It consists of several areas each with different requirements.

Configuration of the Installation Area depends on the following:

- Specific Site conditions
- Crane type
- Logistical possibilities
- Assembly method: Rotor Lift/ Single Blade Lift

In order to design the most effective Site layout that will work both for an optimal delivery and installation, it is crucial that the above-mentioned points have been investigated and analysed.

2.2 Construction Area

Upon written agreement between the Contractor and the Employer, it is allowed to modify the size or shape of the Construction Area when the installation has been executed. Every deviation should be documented and provided in drawings (preferably CAD format) under the responsibility of the Employer. The modification must however **not** restrict the use of a crane during possible service and defects notification period. It shall be possible to re-establish this area in order to assemble the crane.

NOTE: Floating road principal must not be used for the Hardstand areas!

Employer shall prepare obstacle free areas in order to allow safe working access for installation technicians. This includes removal of tree stumps and use of compacted stones if the area is particularly soft or boggy. Placing of deposits from excavation and clearing the Installation Area must be coordinated with Siemens Wind Power.

Construction Area in this document is based on an ideal circumstance of a flat piece of land. However, the Contractor acknowledges the fact that the terrain will have an impact on the position of the respective areas. **Therefore it is recommended that a Site specific layout is provided to the Contractor prior to Contract so that Siemens Wind Power can review and provide comments on how to optimize the Construction Area layout.**

The following requirements apply to all hardstand types. Whilst our price / programme have been based on these configurations, other options are available which can be discussed between the Employer and Contractor.

Printed version is uncontrolled. Controlled version only exists in the electronic document database.

	Document type	Rev. number	00
	Appendix	Date	15-03-2018
Title	Appendix 1: Site Specific Requirements SWT 3,6MW-130-85,0HH	Created by	HvB
		Checked by	MB
		Page	10 of 28
		Owner	WP ON EMEA PM T&C
			Restricted

2.2.1 Option 1 Modified Rectangular Hardstand

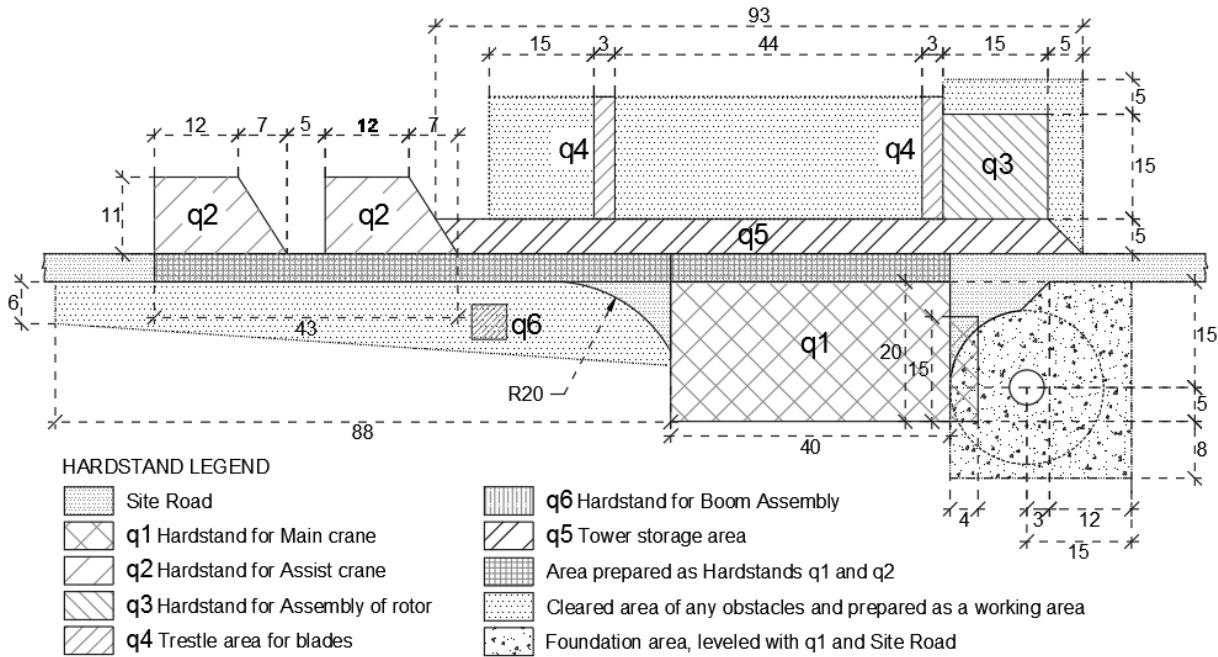

Figure 11a: Example of Installation Area with modified rectangular Hardstand for the Main Crane (LG1750).

Note the options for hardstands q2-q5:

- Hardstands for the Assist Cranes (q2) can be placed alternatively if terrain is complex.
- Hardstand for assembly of rotor (q3) can be placed alternatively if terrain is complex.
- Trestle area for blades (q4) may be moved in the layout if terrain is complex. It can also be left out if just in time delivery is required.**
- Storage area for components (q5) can be left out from the layout if terrain is complex and “just-in-time”-delivery is being used.**

Area	Description	Max. fall	Area (m ²)	Dimensions (m)	Maintenance	Relationship to other q areas
Road	Road section from q1 to q2	1.5%		4	Permanent	Level with q1 and level with q2
q1	Hardstand for Main Crane*	1.5%	860*	(40x20)+(4x15)	Permanent	See comments below
q2	Hardstand for Assist Crane*	1.5%	341*	(12 x11x2) + (11x7)	Temporary	No more than 2% higher or lower than q1, as measured from the centre of the q1 area
q3	Hardstand for assembly of rotor*	0.5%	225*	15 x 15**	Temporary	No more than +/- 1m in level difference from q1
q4	Trestle area for blades*	1.5%	105*	(17.5 x 3) x 2	Temporary	No more than +/- 1m in level difference from q1
q5	Storage area for components*	1.5%	440*	88 x 5	Temporary	Level with q1 and level with q2
q6	Hardstand for boom assembly***		xx	Project specific	Temporary	See 2.2.7

Table 6a: Requirements for dimensioning the areas.

Printed version is uncontrolled. Controlled version only exists in the electronic document database.

	Document type <h2 style="text-align: center;">Appendix</h2>	Rev. number 00 Date 15-03-2018 Created by HvB Checked by MB Page 11 of 28 Owner WP ON EMEA PM T&C
Title <h3 style="text-align: center;">Appendix 1: Site Specific Requirements SWT 3,6MW-130-85,0HH</h3>		Restricted

NOTE: *) Effective areas are with full bearing capacity.

***) Size of q3 is a subject to variation and depending on the type of elephant foot submitted to the Site.

***) Location and size of q6 is a subject to discussion with crane company.

- Please note that there is a cost & time impact associated with the use of just in time delivery.

Pre-assembly

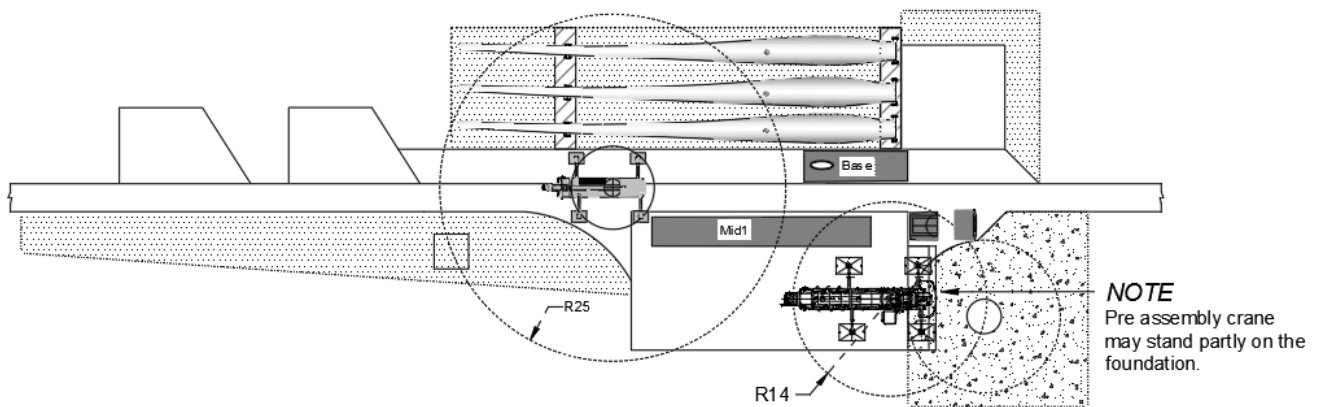



Figure 11b: Example of pre-assembly and storage of components on the Installation Area. For Pre-assembly the base tower, mid section, PU, and nacelle are pre-delivered and stored on the Installation Area. There must be ensured at least 1m free walking area around the components for visual inspection. Steel plates under components may be required to minimize the ground pressure.

Dimensions are based on the LTM1500 pre-assembly crane with a TY3 84m telescopic boom and may therefore be subject to alteration if another crane configuration is chosen.

Printed version is uncontrolled. Controlled version only exists in the electronic document database.

	Document type <h2 style="text-align: center;">Appendix</h2>	Rev. number 00 Date 15-03-2018 Created by HvB Checked by MB Page 12 of 28 Owner WP ON EMEA PM T&C
Title <h3 style="text-align: center;">Appendix 1: Site Specific Requirements SWT 3,6MW-130-85,0HH</h3>		<div style="text-align: center;">Restricted</div>

Main Assembly

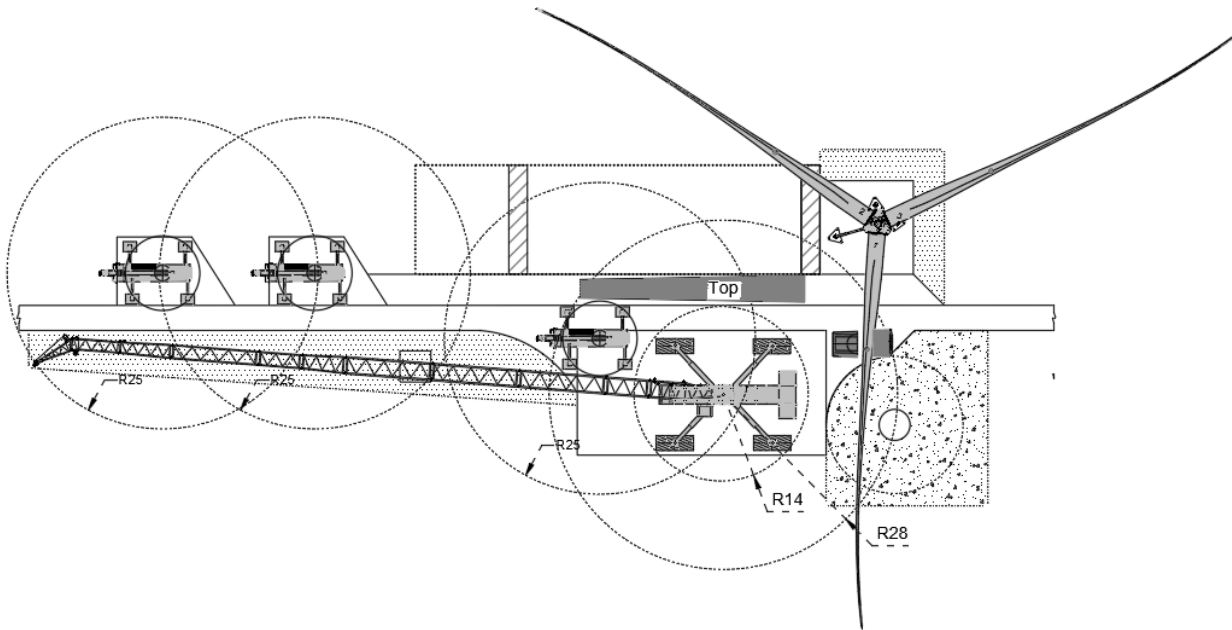



Figure 11c: Example of assembly of the boom and storage of components on the Installation Area. Top tower section, blades and hub will be delivered after pre-assembly and before the main crane is on the hardstand. There must be ensured at least 1m free walking area around the components for visual inspection. Steel plates under components may be required to minimize the ground pressure. Dimensions are based on an LG1750 with boom configuration **SL 105 + 6** and may therefore be subject to alteration, if another crane configuration is chosen. Split nacelle installation is required.

Printed version is uncontrolled. Controlled version only exists in the electronic document database.

	Document type <h2 style="text-align: center;">Appendix</h2>	Rev. number 00 Date 15-03-2018 Created by HvB Checked by MB Page 13 of 28 Owner WP ON EMEA PM T&C
Title <h3 style="text-align: center;">Appendix 1: Site Specific Requirements SWT 3,6MW-130-85,0HH</h3>		Restricted

2.2.2 Transformers

For projects with external transformers: to allow for safe working conditions during the lifting operation, the Employer shall ensure that the transformers are installed on the side of the WTG opposite to the hardstand (and away from the Assembly Area when rotor assembly is the chosen installation method).

For projects with internal transformers: an area of 4m x 4m is to be prepared in front of the WTG door to withstand 30 kN/m².

2.2.3 WTG Door Location

The Employer shall ensure that the foundations and power cable ducts are constructed in such a way that the WTG doors shall be directly facing the hardstand area.

2.2.4 Safe Working Access

The areas to be cleared of any obstacles are identified in **Figure 11a**. These areas shall be prepared by the Employer to allow safe working access for installation technicians.

For example:

- removal of tree stumps / large rocks
- use of compacted stones if the area comprises peat or is particularly soft/boggy
- leveled to ensure easy walking access to components
- edge protection/delineation if required due to terrain (at the reasonable discretion of the Contractor).

Other safety related requirements are identified throughout this document.

Printed version is uncontrolled. Controlled version only exists in the electronic document database.

	Document type <h2 style="text-align: center;">Appendix</h2>	Rev. number 00 Date 15-03-2018 Created by HvB Checked by MB Page 14 of 28 Owner WP ON EMEA PM T&C
Title <h3 style="text-align: center;">Appendix 1: Site Specific Requirements SWT 3,6MW-130-85,0HH</h3>		<div style="text-align: center;">Restricted</div>

2.2.5 Hardstand for Main Crane q1



The Employer shall clearly mark the area of Hardstand **q1** that has the full bearing capacity as stated in **Table 8 & Table 9**.

Figure 12: Example of rectangular Hardstand with Rotor Assembly.

2.2.6 Hardstand for Assist Crane q2



It is assumed that Site Road and Hardstand for Assist Crane **q2** are on the same level and the Assist Crane can stand partly on the road and partly on **q2**. If the road has a gradient bigger than 1.5%, the road cannot be part of **q2** and special solution is required, **as detailed in section 2.2.7**.

Figure 13: Example of Hardstand for Assist Crane **q2** on hilly terrain. Despite of the gradient of adjoining road, **q2** must always be levelled to within 1.5%.

Printed version is uncontrolled. Controlled version only exists in the electronic document database.

	Document type <h2 style="text-align: center;">Appendix</h2>	Rev. number 00 Date 15-03-2018 Created by HvB Checked by MB Page 15 of 28 Owner WP ON EMEA PM T&C
Title <h3 style="text-align: center;">Appendix 1: Site Specific Requirements SWT 3,6MW-130-85,0HH</h3>		<div style="text-align: center; border: 1px solid black; padding: 5px;">Restricted</div>

2.2.7 Hardstand for Assist Crane q2 (on slopes)

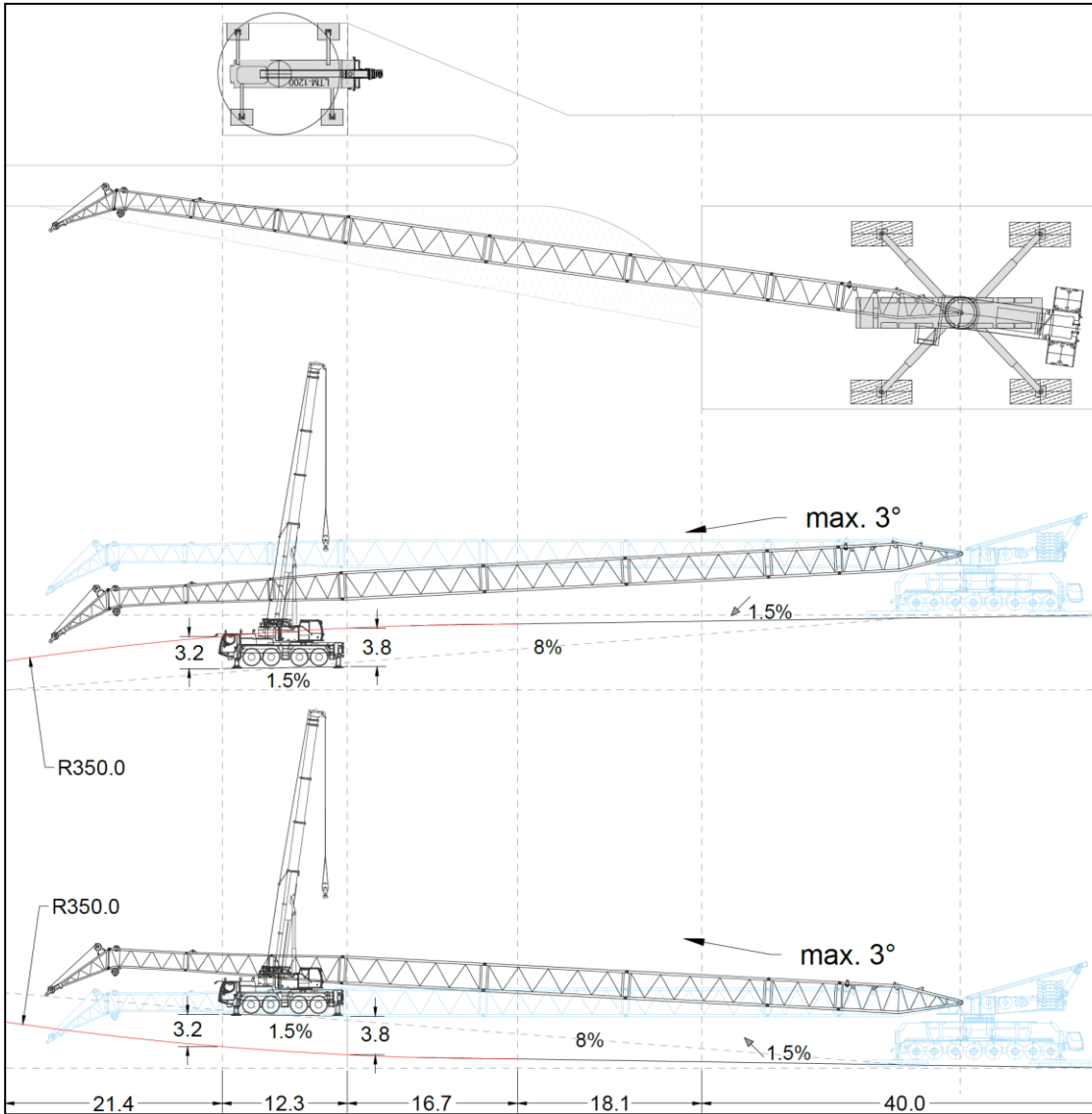



Figure 14: Example of Hardstand for Assist Crane q2 on hilly terrain.

If the slope of the ground dictates that the q2 area cannot be level with the road then a hardstand must be constructed offset to the road. The road must never breach a longitudinal radius of 500m. In these cases a larger assist crane may be required due to the increased lifting radius during boom assembly. This must always be checked by the contractor to explore any additional costs.

Printed version is uncontrolled. Controlled version only exists in the electronic document database.

	Document type <h2 style="text-align: center;">Appendix</h2>	Rev. number 00 Date 15-03-2018 Created by HvB Checked by MB Page 16 of 28 Owner WP ON EMEA PM T&C
Title <h3 style="text-align: center;">Appendix 1: Site Specific Requirements SWT 3,6MW-130-85,0HH</h3>		Restricted

2.2.8 Rotor Assembly Installation Method

Hardstand for the rotor (**q3**) is required. Here the hub and the three blades can be assembled to one complete rotor without the blades blocking the road prior to mounting.

There must be provided accessible, level working area of 5m around the **q3** area. Furthermore rotor assembly requires a sufficient height clearance for the blades as shown in **Figure 15** and **Figure 16**. The Employer shall remove any high obstacles and trip hazards within this area to ensure safe operation.

In case the surface of **q3** cannot be on the same level with the surface of adjoining **q1** due to level differences of terrain, a special solution is required.

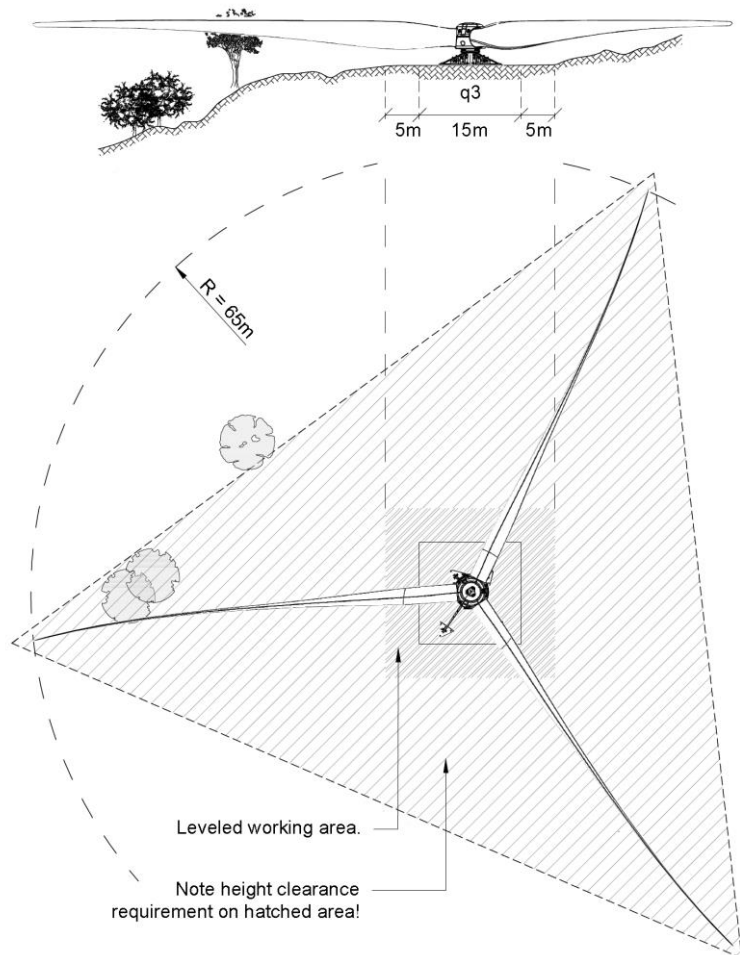

Figure 15: Requirements for Rotor Assembly Installation method.

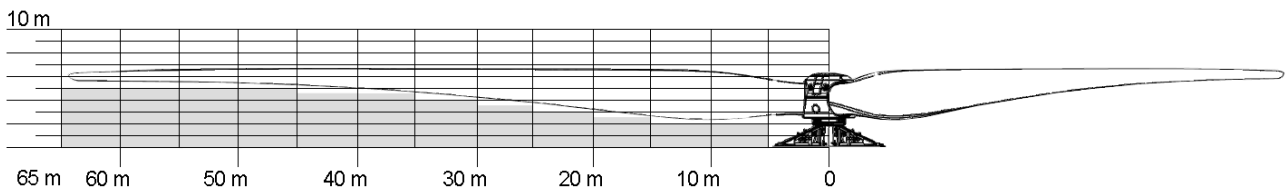



Figure 16: Indicative drawing of height clearance by the Rotor Assembly area. The entire rotor assembly is able to be raised with a 1.9m extension barrel.

Printed version is uncontrolled. Controlled version only exists in the electronic document database.

	Document type <h2 style="text-align: center;">Appendix</h2>	Rev. number 00 Date 15-03-2018 Created by HvB Checked by MB Page 17 of 28 Owner WP ON EMEA PM T&C
Title <h3 style="text-align: center;">Appendix 1: Site Specific Requirements SWT 3,6MW-130-85,0HH</h3>		<div style="text-align: center; border: 1px solid black; padding: 5px;">Restricted</div>

2.2.9 Trestle area for blades q4



Figure 17: Example of trestle area q4

Trestle area **q4** (“blade fingers”) must be leveled and elevated min. 0.5m over the surrounding terrain to avoid blade touching the ground.

There must be provided accessible working area between the fingers and tip end of the blades as per section **2.2.1**. The Employer shall remove any high obstacles and trip hazards within this area to ensure safe operation.

Surface of **q4** must be leveled with adjoining road where the blades are offloaded from.

If **q4** is higher or lower than the adjoining road, this must be approved by Siemens Wind Power as it will have an impact on delivery of the blades.



Figure 18: Example of root end of a trestle area **q4**.

Note that steel plates under components may be required to distribute the load.



Figure 19: Example of a well prepared area between blade fingers.



Figure 20: Example of an unacceptable/unprepared area between blade fingers.

Printed version is uncontrolled. Controlled version only exists in the electronic document database.

	Document type <h2 style="text-align: center;">Appendix</h2>	Rev. number 00 Date 15-03-2018 Created by HvB Checked by MB Page 18 of 28 Owner WP ON EMEA PM T&C
Title <h3 style="text-align: center;">Appendix 1: Site Specific Requirements SWT 3,6MW-130-85,0HH</h3>		Restricted

2.2.10 Hardstand for boom assembly q6

Boom assembly for the Main Crane may require additional hardstand (q6) when hub height of the WTG exceeds 80m. Location and size of the q6 depends on the soil conditions on the Site, boom configuration of the Main Crane as well as the type of Assist Cranes.

Boom assembly on a hilly terrain requires special solution which must be discussed with project manager for each WTG location.

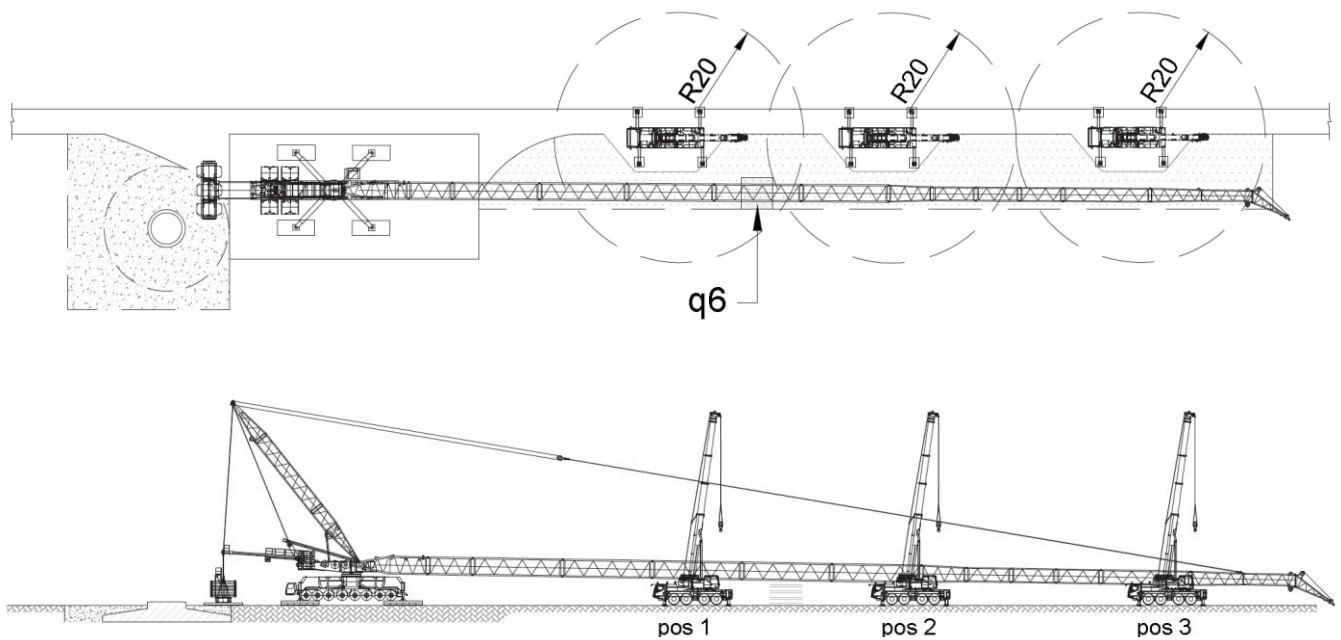

Figure 21: Example of boom assembly on flat terrain.

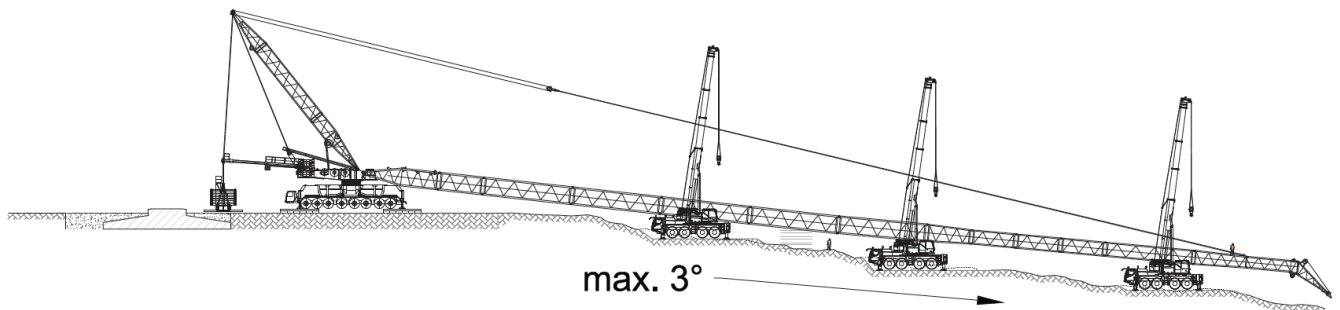



Figure 22: Example of boom assembly on hilly terrain.

Printed version is uncontrolled. Controlled version only exists in the electronic document database.

	Document type <h2 style="text-align: center;">Appendix</h2>	Rev. number 00 Date 15-03-2018 Created by HvB Checked by MB Page 19 of 28 Owner WP ON EMEA PM T&C
Title <h3 style="text-align: center;">Appendix 1: Site Specific Requirements SWT 3,6MW-130-85,0HH</h3>		Restricted

2.3 Level differences and access to WTG

The Employer shall ensure that the level difference between the Construction Area and top of foundation must not be more than 1m (**Figure 23**) where the Construction Area lies below the top of the foundation, and not more than 2m (**Figure 24**) where the Construction Area lies above the top of the foundation. The surface around the foundation should be leveled with the Construction Area.

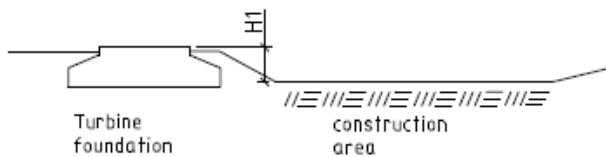

H1 = max. 1m

Figure 23: Maximum level difference when Construction Area is below the top of foundation.

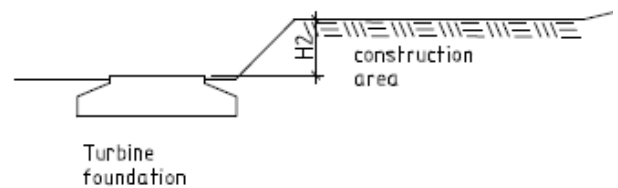

H2 = max. 2m

Figure 24: Maximum level difference when Construction Area is above the top of foundation.

The Site Road along the Construction Area shall be level and at the same height as the Construction Area. This is necessary to ensure that trucks and cranes can maneuver smoothly from the road on to the Construction Area. A level Site Road is also important in order to ensure safe offloading of components.

***NOTE:** If the project has an internal transformer, area of 4m x 4m is to be prepared in front of the WTG door to withstand 30 kN/m²

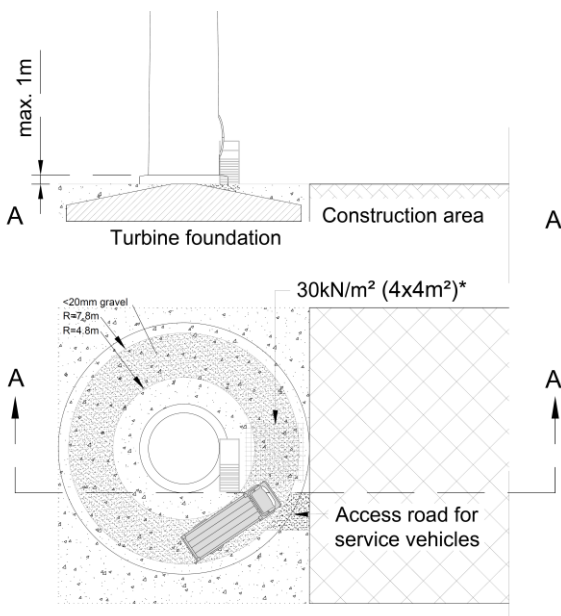



Figure 25: If the foundation is not level with the hardstand then a ramp for service vehicles must be **added after installation is complete.**



Figure 26: Example of not well-maintained service access to WTG.

Printed version is uncontrolled. Controlled version only exists in the electronic document database.

	Document type <h2 style="text-align: center;">Appendix</h2>	Rev. number 00 Date 15-03-2018 Created by HvB Checked by MB Page 20 of 28 Owner WP ON EMEA PM T&C
Title <h3 style="text-align: center;">Appendix 1: Site Specific Requirements SWT 3,6MW-130-85,0HH</h3>		Restricted

Employer shall provide free and level access to the entrance of the WTG during the installation and after completion of the project.

It is important to ensure a proper access road for service vehicles (see **Figure 25**) as heavy components must be within the reach of the nacelle's service crane.

Schedule G4 (FII Pack) "Foundation interface" will give guidelines for positioning of the staircase.

2.4 Area for Tag Lines

Rotor Assembly Installation Method (see section 2.2.8) requires special attention for ensuring cleared area for the safe use of tag lines. The Employer shall remove any high obstacles such as trees from the planned operating area for tag lines. The Employer and Contractor shall together survey the area to be used for tag lines and identify any significant safety hazards (e.g. holes, level changes, marsh etc.). They will mutually agree appropriate mitigations measures, to be carried out by the Employer.

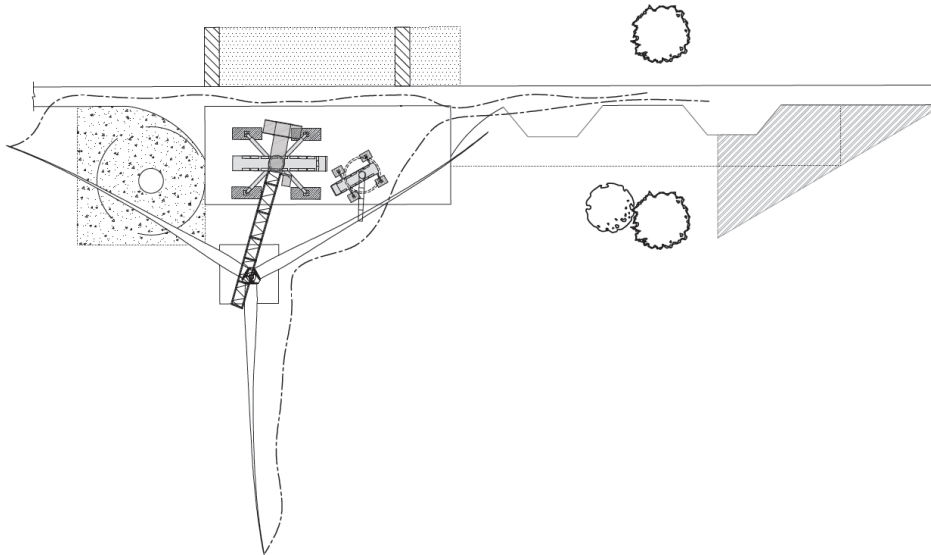



Figure 27: Indicative drawing of starting position for rotor installation. Note that tag lines are first strained when the rotor is turned on vertical position.



Figure 28: Tag line for rotor installation.

Printed version is uncontrolled. Controlled version only exists in the electronic document database.

	Document type <h2 style="text-align: center;">Appendix</h2>	Rev. number 00 Date 15-03-2018 Created by HvB Checked by MB Page 21 of 28 Owner WP ON EMEA PM T&C
Title <h3 style="text-align: center;">Appendix 1: Site Specific Requirements SWT 3,6MW-130-85,0HH</h3>		<div style="text-align: center; border: 1px solid black; padding: 5px;"> Restricted </div>

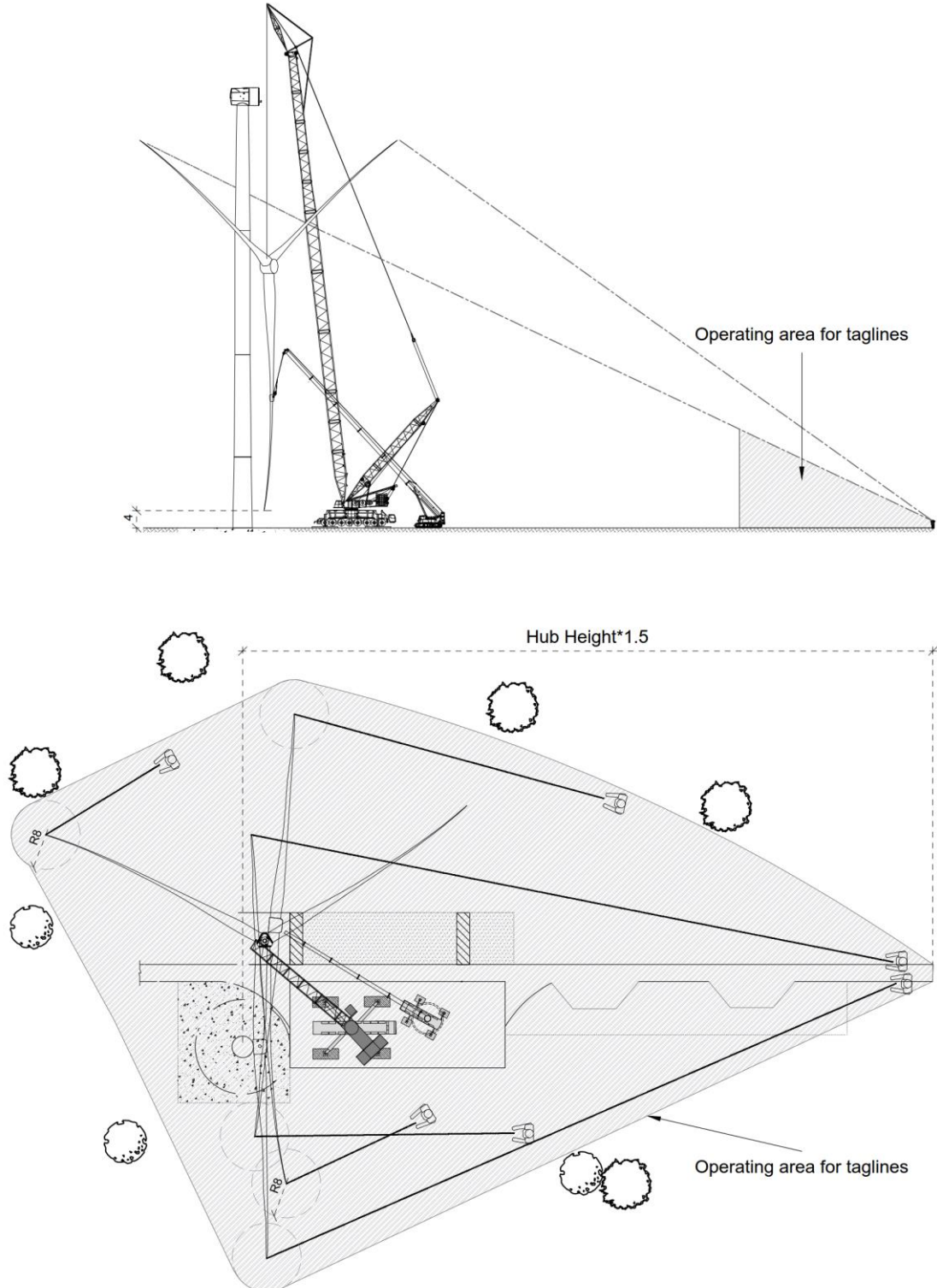



Figure 29: Indicative drawing of area requirements for the use of tag lines with rotor assembly installation method.

Printed version is uncontrolled. Controlled version only exists in the electronic document database.

	Document type <h2 style="text-align: center;">Appendix</h2>	Rev. number 00 Date 15-03-2018 Created by HvB Checked by MB Page 22 of 28 Owner WP ON EMEA PM T&C
Title <h3 style="text-align: center;">Appendix 1: Site Specific Requirements SWT 3,6MW-130-85,0HH</h3>		Restricted

2.5 Proposed Delivery Methodology

The proposed method of delivery for each WTG is described below. This is provided for planning information purposes only and may change depending on circumstances at the time of installation at the discretion of the Contractor.

To be populated during pre-contracting solution development with Employer. Where required, different hardstand configurations can also be developed to suit the Site topography.

WTG No	Method of Delivery / Reverse Driving required ?	Hardstand Type
T1	To be decided	To be decided
Etc.		

Table 7: Delivery Methodology.

Printed version is uncontrolled. Controlled version only exists in the electronic document database.

	Document type <h2 style="text-align: center;">Appendix</h2>	Rev. number 00 Date 15-03-2018 Created by HvB Checked by MB Page 23 of 28 Owner WP ON EMEA PM T&C
Title <h3 style="text-align: center;">Appendix 1: Site Specific Requirements SWT 3,6MW-130-85,0HH</h3>		Restricted

3 Facilities Compound & Storage Area Requirements

This section specifies the requirements for the provision of the Compound and Storage Areas. We will work with you to define the project specific requirements taking into consideration the size, location and planning restrictions of the wind farm. The Employer shall provide the prepared areas for the Compound and Storage Areas. The location and size of the areas shall be discussed and agreed between the Employer and Contractor during the Site layout discussions.

The ground requirements for these areas are specified in **Table 9**, and their gradient shall not exceed 1.5%. The finished surface of the areas shall be easily maintained in all weather conditions. To ensure safe access and working conditions the areas shall be compacted and level, with suitable bearing capacity demonstrated by plate bearing test.

The below requirements are based on a one (1) crew and a one (1) crane setup. Should the project require more than one (1) crew and crane, the parties shall discuss the options and specify the appropriate requirements.

3.1 Site Facilities Compound Area

A Site Compound of a minimum 1,500m² (50m x 30m or similar) shall be provided by the Employer, providing room for the Contractor's temporary Site facilities (offices, messing and car parking).

The Employer shall provide temporary Site office facilities for the Contractor's site management personnel. In addition these facilities shall include messing facilities, changing room, and lavatory facilities for the Contractor's technical staff according to the minimum requirements of the applicable safety, health and welfare legislation.

The Employer shall ensure that connections to utilities such as running water, sewer system, power supply and telecommunication systems are available and ready to use at the time when the Contractor mobilizes on Site. The Contractor shall be responsible for the usage of the utilities during the project execution phase.

The Employer shall arrange telephone capacity for a minimum of six (6) phone lines and connections for six (6) work stations to be simultaneously connected to the internet by means of ADSL or equivalent, with a minimum maintained band width of 10 Mb (10mbs upload & download speed). The Employer shall be responsible for providing and connecting the telecommunication network to each work station. The Contractor shall be responsible for providing its own IT equipment (computers, phones, fax, printers etc.) and shall be responsible for the cost of usage.

The Contractor shall arrange mobile toilet facilities next to the WTGs if required.

3.2 Stores Compound Area

A Stores Compound Area of a minimum 1,200 m² (40m x 30m or similar) shall be provided by the Employer, providing room for the Contractor's plant (such as tele-handlers), skips, waste disposal, containers for tools and spares, technical equipment, fuel etc.

The Stores Compound Area should be located directly adjacent to the Site Facilities Compound Area. If required, the Contractor can assist in providing clear delineation between the two (such as fencing or similar).

In case the Stores Compound Area cannot be located directly adjacent to the Site Facilities Compound Area, an alternative location can be discussed and agreed between the Employer and Contractor.

3.3 Storage Area for WTG Components

A central Storage Area may be necessary if it's not possible to store all the WTG components on the Hardstands. The size of the central Storage Area will depend on the Hardstand configuration and the number of turbines, logistics and how the installation is to be carried out. It is therefore subject to discussion.

Printed version is uncontrolled. Controlled version only exists in the electronic document database.

	Document type	Rev. number 00
	Appendix	Date 15-03-2018
Title	Appendix 1: Site Specific Requirements SWT 3,6MW-130-85,0HH	Created by HvB
		Checked by MB
		Page 24 of 28
		Owner WP ON EMEA PM T&C
		Restricted

4 LOADS

4.1 General

Compound and Storage Areas, Site Roads, Access Roads and Hardstands within the Site Boundary, plus any other geotechnical constructions, shall be designed, constructed and maintained by the Employer to withstand dynamic and static loads from heavy cranes, oversize trucks and the Contractor's personnel vehicles etc. involved in the execution.

All loads presented in the following are characteristic loads the Employer shall multiply with relevant safety factors in accordance with applied design codes.

4.2 Crane Load

Hardstand areas for the Main and Assist Crane (**q1, q2**) must be designed, constructed and maintained by the Employer so that crane outriggers can be placed randomly within the effective Hardstand areas. In case the soil conditions demand alternative solutions such as sand replacement or spread/pile foundations, the Contractor shall be informed about such actions. Areas must also be functional for future crane activities.

Table 8 describes the characteristic maximum loads that Hardstands for cranes shall be designed for:

Hardstand	Description	Load area [m x m]	Load kN/m ²	Total load [kN]
q1	Main Crane*	4 x (2.4 x 6.0)	250	8800
q2	Assist Crane*	4 x (2.0 x 2.0)	200	3000

Table 8: Characteristic maximum loads of cranes.

**Further details on hardstand design are in the SSR GP section 3.1.4*

The Employer shall construct the Hardstands, taking proper account of the static nature of the load from the Main Crane. The Employer shall pay specific attention to the risk of bearing capacity failure on soft deposits from the concentrated loads from the crane outriggers.

In the case that a crawler crane is to be used as the Main Crane, specifics of the civil works need to be further clarified due to the loads exerted on Site Roads when driving the crane between the Installation Areas with boom fully assembled.

Provided that soil conditions exclude heavy cranes to be installed directly on a constructed Hardstand, alternative solutions (sand replacement, spread / pile foundations etc.) must take into consideration that crane support feet in the future can be placed randomly within the effective Hardstand areas, unless otherwise agreed with the Contractor.

NOTE: No reverse driving allowed for Main Crane (micro movement only on Hardstands). Turning head or similar must be provided where relevant.

Printed version is uncontrolled. Controlled version only exists in the electronic document database.

	Document type	Rev. number 00
	Appendix	Date 15-03-2018
Title	Appendix 1: Site Specific Requirements SWT 3,6MW-130-85,0HH	Created by HvB
		Checked by MB
		Page 25 of 28
		Owner WP ON EMEA PM T&C
		Restricted

4.3 Other Loads

Table 9 describes the ground bearing requirements that other Hardstand areas shall be designed for:

Hardstand	Description	Load kN/m ²
q3	Assembly Area for rotor	200
q4	Trestle area for blades	200
q5	Storage Area (WTG components)	200
	Compound Area excl. Storage Area	100
	Storage Area & Stores Compound Area	200



Table 9: Ground bearing requirements for other Hardstand areas.

Figure 30: Example of component bracket. Arrows are showing the foot print area.

NOTE: The distributed load from the component may be concentrated on a very small area due to the design of the brackets. Footprint from the bracket will generate substantially higher ground pressure than 200kN/m² and therefore steel plates under components may be required to distribute the load. Where necessary the Contractor will provide steel plates under components to distribute load.

Printed version is uncontrolled. Controlled version only exists in the electronic document database.

	Document type	Rev. number 00
	Appendix	Date 15-03-2018
Title	Appendix 1: Site Specific Requirements SWT 3,6MW-130-85,0HH	Created by HvB
		Checked by MB
		Page 26 of 28
		Owner WP ON EMEA PM T&C
		Restricted

5 TRANSPORT

The Employer can base the design of the Site Roads on one of the following two methods.

5.1 Method 1: The empirical analytical method

Method is based on the following assumptions:

- Number of passes shall be calculated based on the following equation:

$$\text{Numbers of passes} = 5,000 \text{ passes} + (\text{nos. of turbines serviced by road section}) \times 1,000 \text{ passes}$$

(Maximum value for design: 15,000 passes).

(i.e. the minimum number of passes for a road section should be 5,000 with an addition of 1,000 passes for each turbine that has to be transported on the particular road section – up to a maximum value of 15,000 passes).

- Maximum **design** axle load (20 tons = 10 tons single wheel load). Not to be confused with characteristic loads!

Contact pressure for the design wheel should be 1.3 MPa.

5.2 Method 2: Maximum characteristic loads of transport vehicles.

For road design based on other methods, **Table 10** describes the maximum characteristic loads of transport vehicles. The listed loads may also be applied for design of junctions.

Vehicles	Axle load [T]	Total load [kN]
Backend Nacelle transport	12	720
Generator transport	12	1080
Tower transport	12	1200
Hub transport	10	500
Blade transport	10	800
All cranes transported on public road	12	-
Assist Crane (100T wheel crane)	17 (incl. counterweight)	850
Assist Crane (100T wheel crane)	12 (fully de-rigged)	600
Main Crane on Site Road	26 (partly de-rigged)	1760
Main Crane on Site Road	12 (fully de-rigged)	960
Main Crane on q1*	26	2080

Table 10: Characteristic maximum loads of transport vehicles.

These requirements do NOT take into consideration the use of a crawler crane.

If a crawler crane is shall be used in the project, this information will show up in the SSR.

The listed vehicle loads can be considered as informative maximum loads for different transport types. All relevant transport types may not be listed. For design purpose, detailed transport specifications should be collected.

*Please note that the crane can be transported in fully de-rigged configuration to reduce the Axle load requirement from 26T to 12T per axle, but this has programme and hence cost implications, which we would be happy to discuss prior to Contract. The crane will be transported fully de-rigged on Public Roads and upon accessing the Site to the first WTG location. Therefore a reduced bearing capacity of 12T is permissible on the main Site Access Road.

Printed version is uncontrolled. Controlled version only exists in the electronic document database.

	Document type <h2 style="text-align: center;">Appendix</h2>	Rev. number 00 Date 15-03-2018 Created by HvB Checked by MB Page 27 of 28 Owner WP ON EMEA PM T&C
	Title <h3 style="text-align: center;">Appendix 1: Site Specific Requirements SWT 3,6MW-130-85,0HH</h3>	Restricted

5.3 Transport drawings

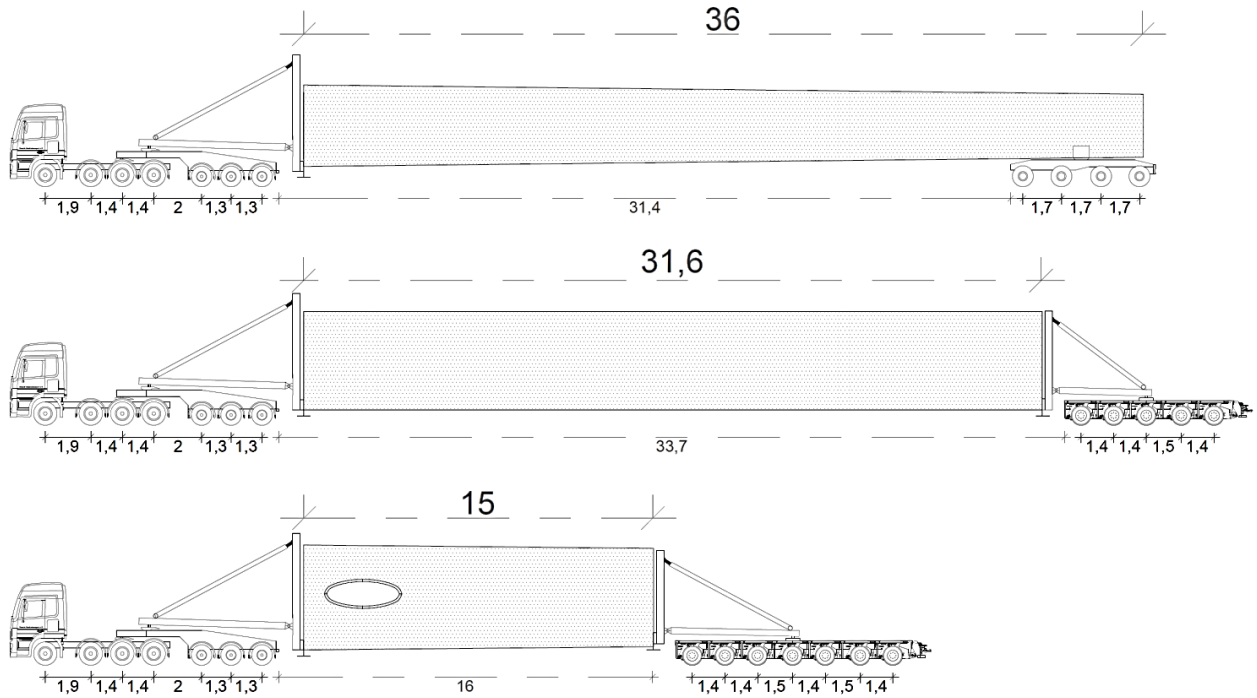

Figure 31: Indicative tower transportation.

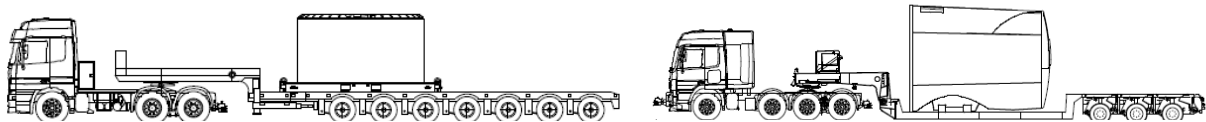

Figure 32: Indicative nacelle transportation.

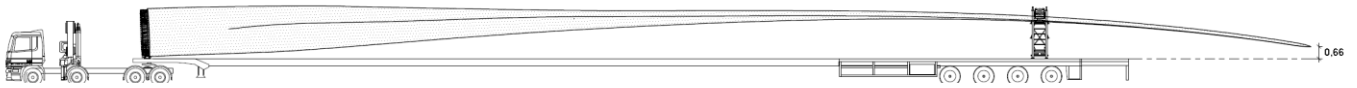



Figure 33: Indicative blade transportation.

Printed version is uncontrolled. Controlled version only exists in the electronic document database.

	Document type <h2 style="text-align: center;">Appendix</h2>	Rev. number 00 Date 15-03-2018 Created by HvB Checked by MB Page 28 of 28 Owner WP ON EMEA PM T&C
Title <h3 style="text-align: center;">Appendix 1: Site Specific Requirements SWT 3,6MW-130-85,0HH</h3>		Restricted

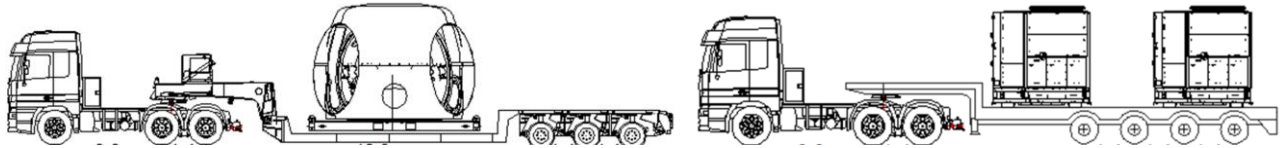

Figure 34: Indicative hub and PU transportation.

Printed version is uncontrolled. Controlled version only exists in the electronic document database.

Appendix 2: Site Specific Requirements Handover Checklist

Name of Wind farm : Pottendijk	Date :
Compound Storage & Facilities: <input type="checkbox"/> WTG Nr: _____	Drawing Nr: _____

Condition of	Yes	No	Remarks:
Access Roads to WTG <ul style="list-style-type: none"> ➤ Road width and cross falls to specification ➤ Surface quality to specification ➤ Findings from trial run incorporated ➤ Delineators provided as advised in the SSR ➤ Gradients as per the requirements ➤ Loaded / unloaded Turning Areas as per specification ➤ Lay-by or Passing Areas as per the specification ➤ Barriers for the over-head lines in place ➤ Appropriate signage present on Site Roads & access ➤ Appropriate barriers or other control measures in place to restrict access of farm animals to construction areas (if applicable) 	<input type="checkbox"/> <input type="checkbox"/> <input type="checkbox"/> <input type="checkbox"/> <input type="checkbox"/> <input type="checkbox"/> <input type="checkbox"/> <input type="checkbox"/> <input type="checkbox"/> <input type="checkbox"/> <input type="checkbox"/> <input type="checkbox"/> <input type="checkbox"/> <input type="checkbox"/> <input type="checkbox"/> <input type="checkbox"/> <input type="checkbox"/> <input type="checkbox"/> <input type="checkbox"/> <input type="checkbox"/>	<input type="checkbox"/> <input type="checkbox"/> <input type="checkbox"/> <input type="checkbox"/> <input type="checkbox"/> <input type="checkbox"/> <input type="checkbox"/> <input type="checkbox"/> <input type="checkbox"/> <input type="checkbox"/> <input type="checkbox"/> <input type="checkbox"/> <input type="checkbox"/> <input type="checkbox"/> <input type="checkbox"/> <input type="checkbox"/> <input type="checkbox"/> <input type="checkbox"/> <input type="checkbox"/> <input type="checkbox"/>	<ul style="list-style-type: none"> •
Turbine Foundation <ul style="list-style-type: none"> ➤ Base backfilled & compacted ➤ Safe personnel access to/from base ➤ Top of base tidy ➤ Base finish acceptable ➤ Ducts acceptable ➤ Protrusion of bolts within specified tolerances ➤ Bolt condition acceptable ➤ HV/LV/SCADA cables installed ➤ Earthing cables installed 	<input type="checkbox"/> <input type="checkbox"/> <input type="checkbox"/> <input type="checkbox"/> <input type="checkbox"/> <input type="checkbox"/> <input type="checkbox"/> <input type="checkbox"/> <input type="checkbox"/> <input type="checkbox"/> <input type="checkbox"/> <input type="checkbox"/> <input type="checkbox"/> <input type="checkbox"/> <input type="checkbox"/> <input type="checkbox"/> <input type="checkbox"/> <input type="checkbox"/>	<input type="checkbox"/> <input type="checkbox"/> <input type="checkbox"/> <input type="checkbox"/> <input type="checkbox"/> <input type="checkbox"/> <input type="checkbox"/> <input type="checkbox"/> <input type="checkbox"/> <input type="checkbox"/> <input type="checkbox"/> <input type="checkbox"/> <input type="checkbox"/> <input type="checkbox"/> <input type="checkbox"/> <input type="checkbox"/> <input type="checkbox"/> <input type="checkbox"/>	<ul style="list-style-type: none"> •
Crane Hardstand <ul style="list-style-type: none"> ➤ Acceptable surface ➤ Acceptable dimensions ➤ Acceptable levels / falls ➤ Safe vehicular access on Hardstand ➤ Restrictions present ➤ Load bearing test results available ➤ Areas for crane boom assembly free from obstructions and as per the specification ➤ Sufficient space to manoeuvre delivery trucks after dropping off main components 	<input type="checkbox"/> <input type="checkbox"/> <input type="checkbox"/> <input type="checkbox"/> <input type="checkbox"/> <input type="checkbox"/> <input type="checkbox"/> <input type="checkbox"/> <input type="checkbox"/> <input type="checkbox"/> <input type="checkbox"/> <input type="checkbox"/> <input type="checkbox"/> <input type="checkbox"/> <input type="checkbox"/> <input type="checkbox"/>	<input type="checkbox"/> <input type="checkbox"/> <input type="checkbox"/> <input type="checkbox"/> <input type="checkbox"/> <input type="checkbox"/> <input type="checkbox"/> <input type="checkbox"/> <input type="checkbox"/> <input type="checkbox"/> <input type="checkbox"/> <input type="checkbox"/> <input type="checkbox"/> <input type="checkbox"/> <input type="checkbox"/> <input type="checkbox"/>	<ul style="list-style-type: none"> •

<p>Blade Storage Area</p> <ul style="list-style-type: none"> ➤ Acceptable surface ➤ Acceptable dimensions ➤ Acceptable levels / falls ➤ Areas between the blade fingers and around the tip area have safe and free from obstructions access for technicians ➤ Acceptable access for control of taglines during lift ➤ Restrictions present 	<input type="checkbox"/> <input type="checkbox"/> <input type="checkbox"/> <input type="checkbox"/> <input type="checkbox"/> <input type="checkbox"/> <input type="checkbox"/> <input type="checkbox"/> <input type="checkbox"/> <input type="checkbox"/> <input type="checkbox"/> <input type="checkbox"/> <input type="checkbox"/> <input type="checkbox"/>	<ul style="list-style-type: none"> •
<p>Compound and storage area</p> <ul style="list-style-type: none"> ➤ Area size and dimension is to specification ➤ Safe and appropriate access to the areas ➤ Telephone, broadband, water, sewer and electricity connections are available and as per the specification ➤ Acceptable surface, ground conditions and bearing capacity ➤ Car parking space for Siemens plant and equipment are as per the specification ➤ Appropriate lighting available around the Compound and Contractor facilities ➤ Security fence around the Compound Area 	<input type="checkbox"/> <input type="checkbox"/> <input type="checkbox"/> <input type="checkbox"/> <input type="checkbox"/> <input type="checkbox"/> <input type="checkbox"/> <input type="checkbox"/> <input type="checkbox"/> <input type="checkbox"/> <input type="checkbox"/> <input type="checkbox"/> <input type="checkbox"/> <input type="checkbox"/>	
<p>Outstanding Items</p>	<input type="checkbox"/> <input type="checkbox"/>	
<p>Safety Inspection Report</p>	<input type="checkbox"/> <input type="checkbox"/>	

Appendix 3: SSR Handover Certificate

Name of Wind farm : Pottendijk	Date :
--------------------------------	--------

WTG Nr: _____ Site Road Section. _____	Drawing Nr: _____
---	-------------------

The following is to be filled out by the Employer's civil contractor who has undertaken the design and construction of crane hardstands and access tracks. All design and construction is as per Siemens SSR specifications. Testing and inspections will be performed to ensure the construction will continue to satisfy the SSR requirements for the duration required.

To be filled out by Employer's civil contractor:

Design and Condition of	Initials	Remarks:
Access Roads & Crane Hardstands <ul style="list-style-type: none"> ➤ Design of roads & hardstand has been carried out by a competent Geotechnical Engineer in accordance with relevant design standards. ➤ Correct supervision has been performed throughout the construction process to ensure all works have been completed in accordance with the design. E.g. extent of compaction, layer thickness, geo-grid overlaps, formation level testing etc. ➤ An adequate surface and ground water drainage plan has been designed and implemented that will ensure the site will stay in good condition throughout the duration of the works. ➤ All dimensions and gradients are within the specifications of the Siemens SSR. A level survey has been completed to ensure this and is available for inspection on request. ➤ All bearing capacities and settlement levels are in accordance within the limits defined in the Siemens SSR. ➤ Load bearing test results available. ➤ All records of design and construction work have been documented and available for inspection on request. 		
Outstanding Items	<input type="checkbox"/> <input type="checkbox"/>	
Safety Inspection Report	<input type="checkbox"/> <input type="checkbox"/>	

We hereby certify that the design and construction work completed at (**Turbine number/Road section**) has been carried to meet the Siemens SSR requirements and will remain within these requirements throughout the duration of the works.

Signature of Employer's civil contractor: _____

Date: _____